

# Modeling and Simulation in the Systems Engineering Process A Half-Day Tutorial

Prepared and Presented by:

James E. Coolahan, Ph.D.

Johns Hopkins University Engineering for Professionals

Coolahan Associates, LLC

[jim.coolahan@jhu.edu](mailto:jim.coolahan@jhu.edu)

[jim@coolahan.com](mailto:jim@coolahan.com)

410-440-2425 (cell)



# Tutorial Learning Objectives

---

Learning Objectives: At the conclusion of this tutorial, students should be able to:

- Define and distinguish key modeling and simulation (M&S) terms
- Name some ways in which M&S can aid in needs and opportunities analysis
- Illustrate the contents of the five major components of a system effectiveness simulation for a system
- Explain typical applications of simulations in several engineering disciplines
- Identify issues that need to be addressed in planning for M&S use during test and evaluation
- Name some types of models and simulations used in the planning / execution of system production
- Explain how system operation simulations can be used to investigate system anomalies during sustainment



# Tutorial Outline

---

- Part 1: Overview of Modeling and Simulation
- Part 2: Use of M&S by Phase of the Systems Engineering Process
  - M&S in System Needs and Opportunities Analysis
  - M&S in Concept Exploration and Evaluation
  - M&S in Design and Development
  - M&S in Integration and Test & Evaluation
  - M&S in Production and Sustainment

# Part 1: Overview of Modeling and Simulation



# Lecture Outline

---

- Definitions and Distinguishing Characteristics
- Views and Categories of Models and Simulations
- Resolution, Aggregation, and Fidelity
- Overview of the Model/Simulation Development Process
- Important M&S-Related Processes
- M&S as a Professional Discipline
- Summary



# Key Modeling and Simulation Definitions

---

There are a number of definitions of models, simulations, and modeling and simulation (M&S). For the purposes of this tutorial, we will adopt the definitions published by the U.S. Department of Defense (DoD), below.

- Model: A physical, mathematical, or otherwise logical representation of a system, entity, phenomenon, or process. [1]
- Simulation: A method for implementing a model over time. [1]
- Modeling and simulation: The discipline that comprises the development and/or use of models and simulations. [2]

Sources: (1) Department of Defense Modeling and Simulation (M&S) Glossary, July 1, 2013; available at <http://www.msco.mil/MSGlossary.html>

(2) DoD 5000.59, DoD Modeling and Simulation (M&S) Management, August 2007



# Distinguishing Between Models, Simulations, and M&S-Related Tools

- Models
  - Need not be computer-based
  - Represent something in the real world
  - Are “static” representations
- Simulations
  - Need not be computer-based
  - Represent something in the real world
  - Are “dynamic” representations (of models)
- M&S-Related Tools
  - Are typically computer-based
  - Do not, by themselves, represent something in the real world
  - Can be used to create (computer-based) models and simulations
- Examples
  - Microsoft Excel is a “tool” (not a model), but can be used to create a “cost model” of a system
  - AnyLogic is a modeling tool that can be used to create a “process simulation”



# Five Different “Views” of Models and Simulations

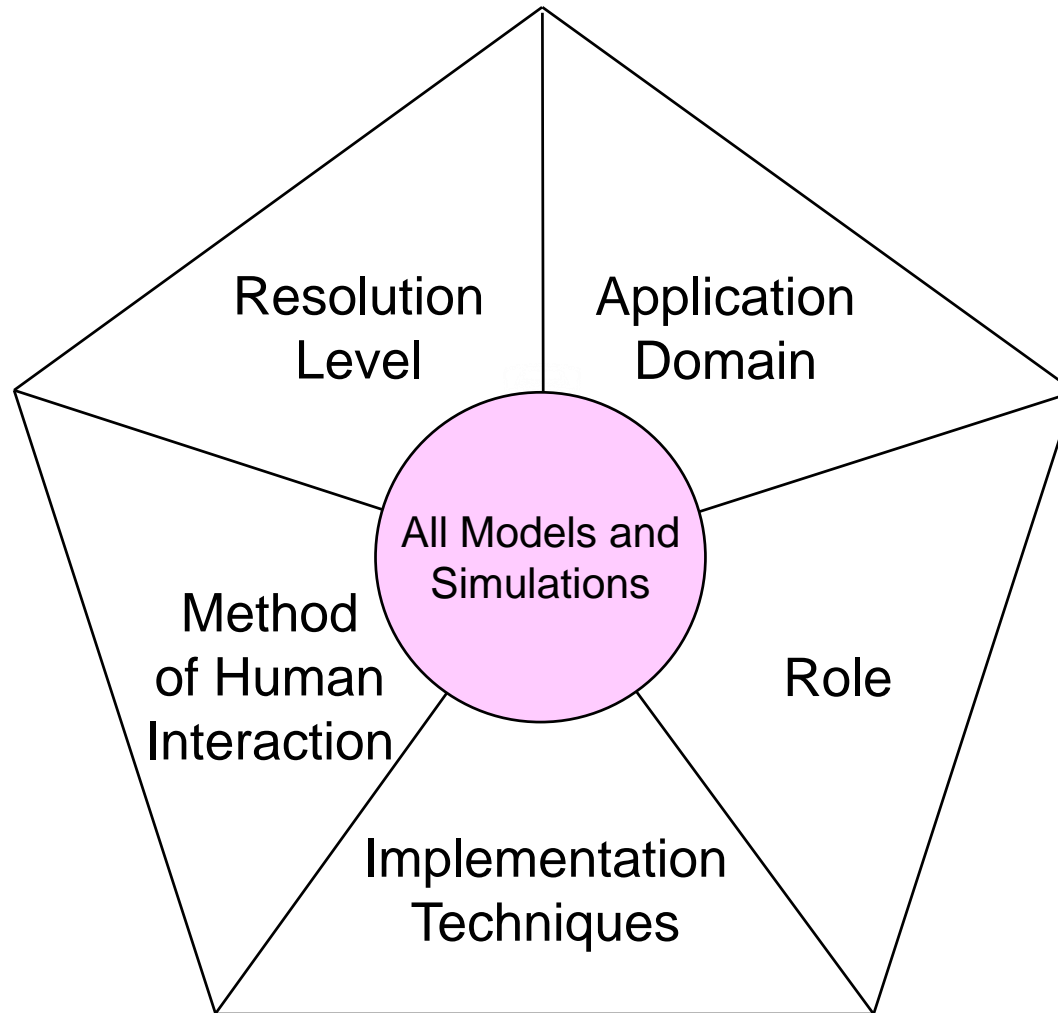





# Selected Major Modeling & Simulation Application Domains

---

- Military systems
  - Air and missile defense
  - Strike warfare
  - Undersea warfare
- Civilian systems
  - Aerospace
  - Automotive
  - Electronics
- Homeland security
  - Airborne hazard dispersion
  - Disease spread
  - Traffic evacuation
- Medicine
  - Drug discovery
  - Health care
  - Surgery simulation



# Selected Major Modeling & Simulation Roles

---

- Planning and analysis
  - “How many of system X do I need?” “Which alternative is best?”
- Experimentation
  - “How could we use this better?” “What might happen if we tried this?”
- Systems engineering and acquisition
  - Principal focus of this course
- Test and evaluation (T&E)
  - “Does the system work as expected?” “Will it help in the real world?”
- Training
  - “How can we ensure the system is used correctly?” “How can we prepare pilots for rare emergency situations?”
- Cost estimation
  - “How much will this cost?” “How can we reduce cost?”







# Modeling and Simulation Implementation Techniques

---

- Technique decisions to be made, based on application
  - Static vs. dynamic
  - Deterministic vs. stochastic (“Monte Carlo”)
  - Discrete vs. continuous
  - Discrete-event vs. time-stepped
  - Standalone vs. embedded (“in the loop”)
  - Unitary vs. distributed
  - Live vs. virtual vs. constructive (more to follow on next slide)
- Other technique decisions
  - Visualization needs
  - Stimulation of real systems

# Categorizing Simulations by the Nature of Human-System Interaction

- **Live** simulation: A simulation involving real people operating real systems
  - Examples: exercises, operational tests
- **Virtual** simulation: A simulation involving real people operating simulated systems
  - Examples: cockpit simulator, driving simulator
- **Constructive** simulation: A simulation involving simulated people (or no people) operating simulated systems
  - Examples: crash test facilities, missile 6-degree-of-freedom simulations

		<u>People</u>	
		Real	Simulated
<u>Systems</u>	Real	<b>Live</b> 	
	Simulated	<b>Virtual</b> 	<b>Constructive</b> 

Question: What would you call a simulation involving simulated people operating real systems? If the system were an airplane, would you fly on it?

# Categorizing Models and Simulations by Levels of Resolution

Most M&S application domains have a hierarchical means of categorizing models and simulations in that domain, by resolution level.

## Military Simulation Pyramid

**PATRIOT-centric example**



Gulf War

Air defense

Missile intercept

Terminal guidance

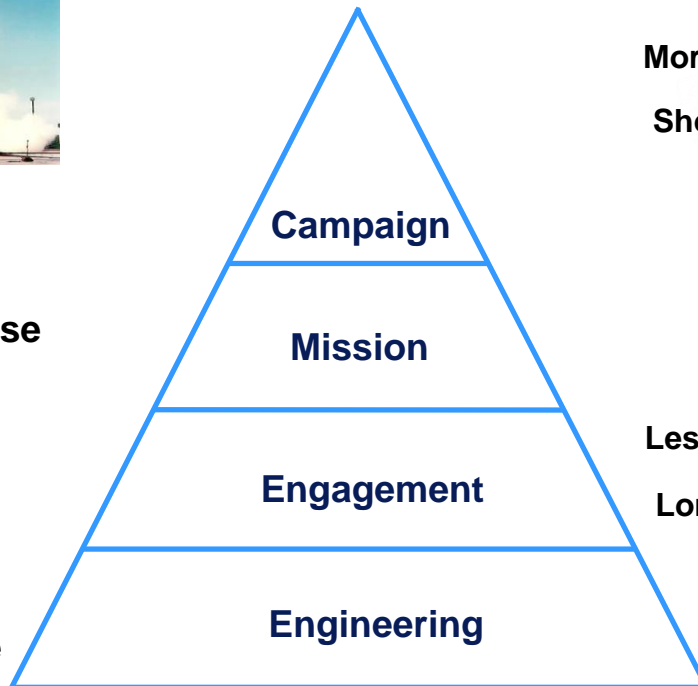

## Human Body M&S Pyramid

**Cardiac-centric example**

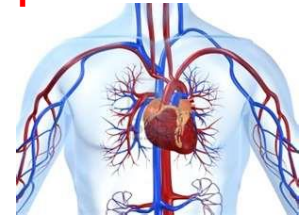

Whole body

Cardio-vascular

Heart

Myocyte

Ca<sup>++</sup>

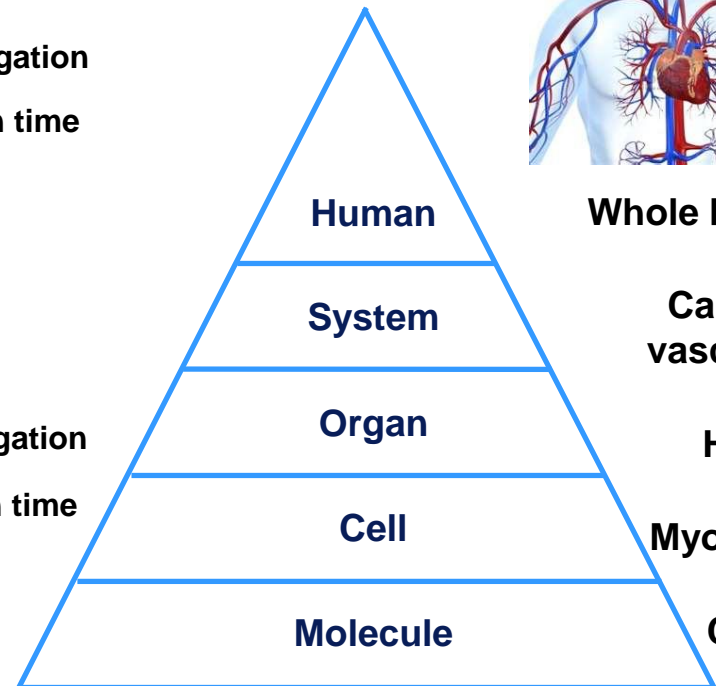

More aggregation

Shorter run time



Less aggregation

Longer run time



# Relative Run-times of Live, Virtual, and Constructive Simulations

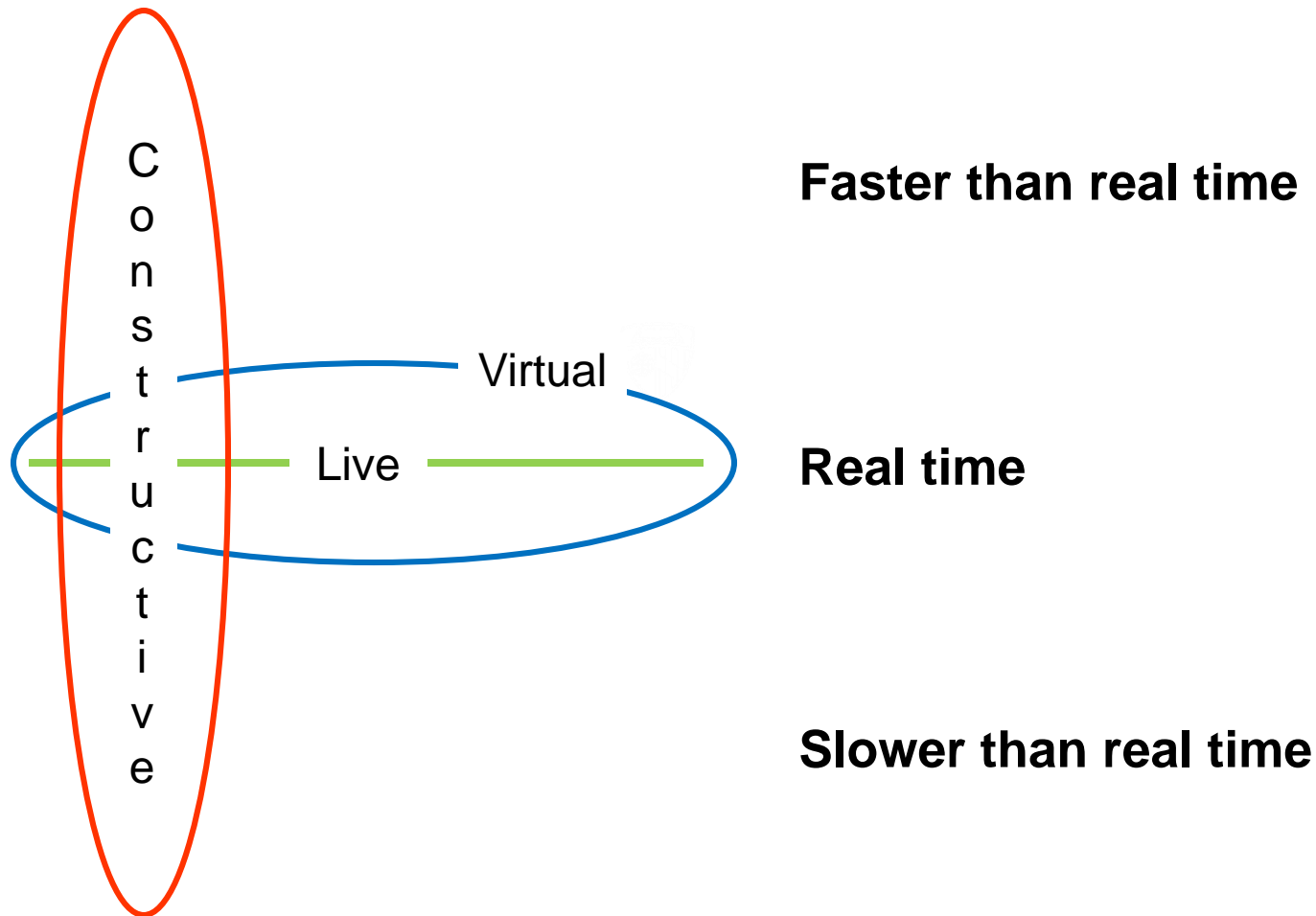



# Resolution, Aggregation, and Fidelity

- Resolution: The degree of detail and precision used in the representation of real world aspects in a model or simulation
  - Models and simulations at lower levels of M&S “pyramid” tend to exhibit more resolution; this does not necessarily imply more accuracy
- Aggregation: The ability to group entities while preserving the effects of entity behavior and interaction while grouped
  - “Campaign-level” simulations often aggregate military entities into larger groups (e.g., brigades vs. battalions)
- Fidelity: The accuracy of the representation when compared to the real world
  - Greater fidelity does not imply greater resolution

Source of definitions: Department of Defense Modeling and Simulation (M&S) Glossary, July 1, 2013; available at <http://www.msco.mil/MSGlossary.html>



# The Model/Simulation Development Process

- Developing a model or simulation is, in itself, a type of “systems engineering” process
- Although shown below as a “waterfall,” various forms of iteration are possible.

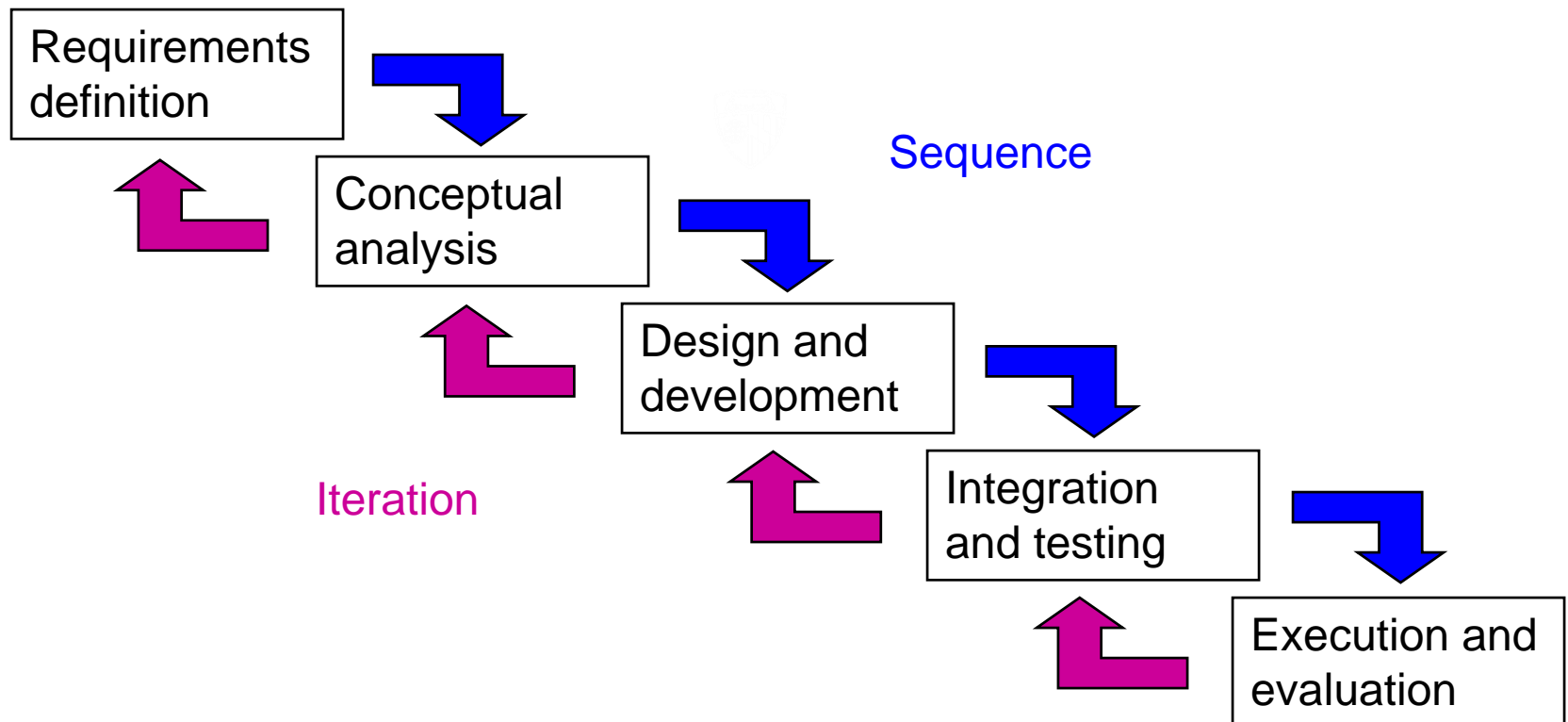





# Important M&S-Related Processes: Configuration Management

---

- Configuration management is just as important for M&S as it is for systems and software engineering.
- Issues in model / simulation configuration management
  - Identifying the “current version” during development
  - Maintaining a copy of each “release”
  - Tracking defects and their correction
  - Maintaining records of recipients of each version
  - Managing multiple “branches” for multiple users
  - Managing co-developed versions if source is distributed
  - Incorporating externally-made changes in a “baseline” version
  - Regression testing of new versions



# Important M&S-Related Processes: Verification, Validation, and Accreditation (VV&A)

---

- Verification - The process of determining that a model or simulation implementation and its associated data accurately represent the developer's conceptual description and specifications
  - *Did we build the model right?*
- Validation - The process of determining the degree to which a model or simulation and its associated data are an accurate representation of the real world from the perspective of the intended uses of the model
  - *Did we build the right model?*
- Accreditation - The official certification that a model or simulation and its associated data are acceptable for use for a specific purpose
  - *Is this the right model to use for this purpose?*

Source: DoD Instruction (DoDI) 5000.61 DoD Modeling and Simulation (M&S)  
Verification, Validation, and Accreditation (VV&A), December 9, 2009

# Interoperable Simulation: The High Level Architecture (HLA)

- Architecture calls for a federation of simulations
- Architecture specifies
  - Ten **Rules** that define relationships among federation components
  - An **Object Model Template** that specifies the form in which simulation elements are described
  - An **Interface Specification** that describes the way simulations interact during operation

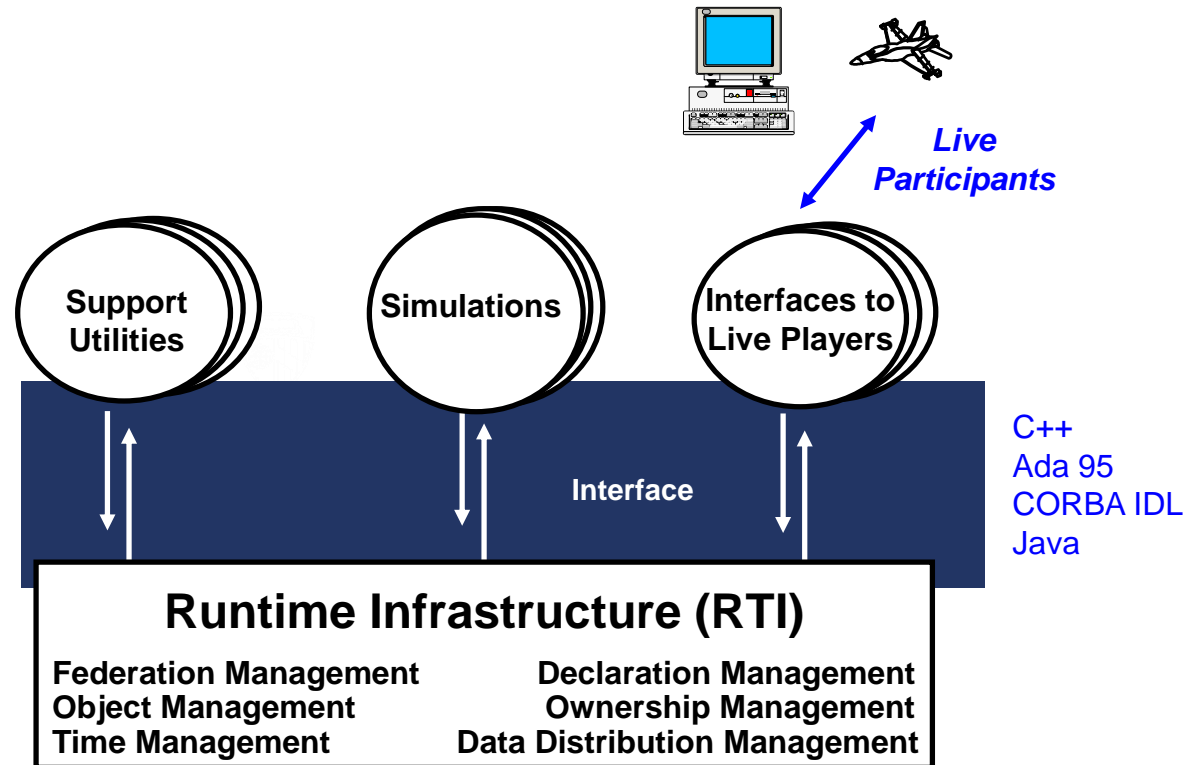

The HLA was originally developed by DoD. It is now IEEE standard 1516.



# Modeling and Simulation as an Academic Discipline

---

- Very few Universities offer Modeling & Simulation as an academic discipline with a degree program
- Graduate-level M&S degree programs are offered in the U.S. by:
  - The University of Central Florida (UCF)
  - Old Dominion University (ODU)
  - The University of Alabama in Huntsville (UAH)
  - The Naval Postgraduate School (NPS)
  - Arizona State University (ASU)
  - Purdue University Calumet
  - Philadelphia University
- M.S. degree concentrations in M&S are offered by:
  - The Johns Hopkins University (JHU) [in Systems Engineering]
  - Columbus State University (GA) [in Applied Computer Science]



# Modeling and Simulation as a Professional Discipline

---

- Professional certification in M&S is available
  - Certified Modeling and Simulation Professional (CMSP) designation
    - Originated by the National Training and Simulation Association (NTSA)
    - Now administered by the Modeling and Simulation Professional Certification Commission (M&SPCC)
  - Requirements:
    - Relevant (simulation) work experience and educational requirements, three letters of recommendation, and a passing grade on the exam
    - Fee of \$250
    - 14 days allowed to answer 100-question examination
  - See web site: <http://www.simprofessional.org>



# Module Summary

---

- A model is a physical, mathematical, or otherwise logical representation of a system, entity, phenomenon, or process. A simulation is a method for implementing a model over time.
- Models and simulations can be categorized by their application domain, role, implementation techniques, method of human interaction, and level of resolution.
- Developing a model or simulation is, in itself, a type of systems engineering process.
- Configuration management and VV&A are two important M&S processes.
- Simulations may be made to interoperate with one another using various techniques, including the HLA (IEEE 1516).
- M&S has not completely emerged as a separate academic discipline, but is beginning to be recognized as a professional discipline.

## Part 2: Use of M&S by Phase of the Systems Engineering Process

# Systems Engineering Process Model for This Tutorial



# The “V” Model of Systems Engineering

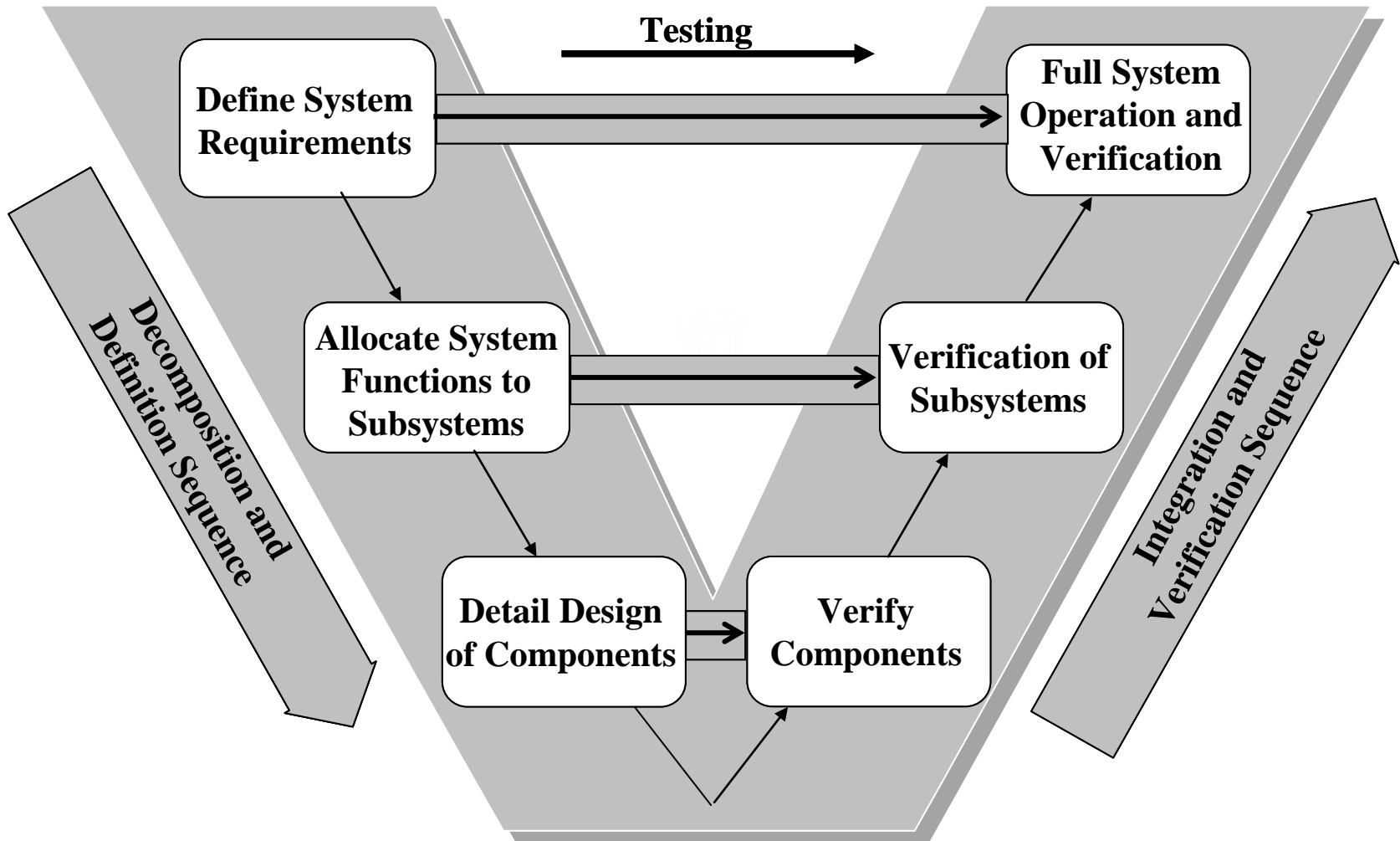

# Defense Acquisition Program Model (for Hardware-Intensive Program)

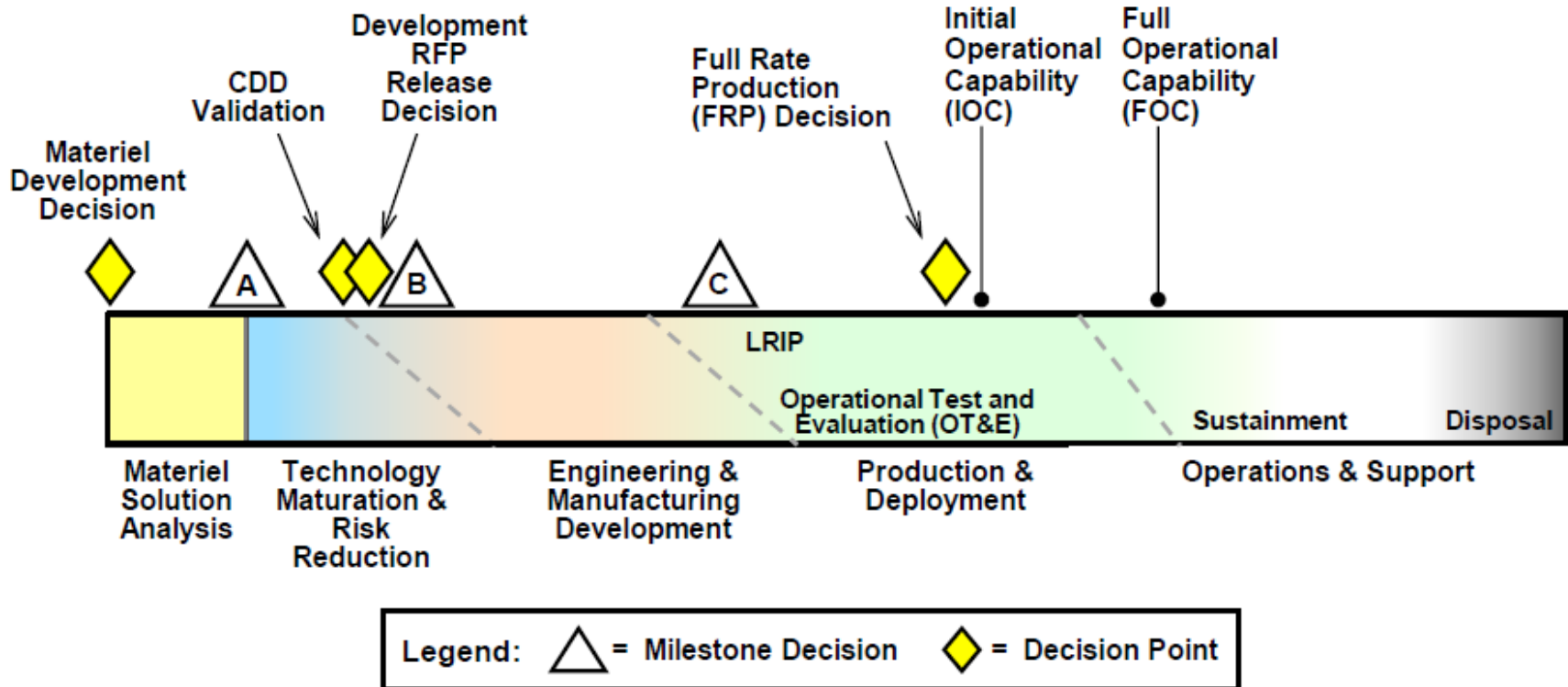

Five other variants of this program model exist for other types of programs.

Source: DoD Instruction 5000.02, *Operation of the Defense Acquisition System*, January 7, 2015



# A Representative Six-Stage System Life Cycle

---

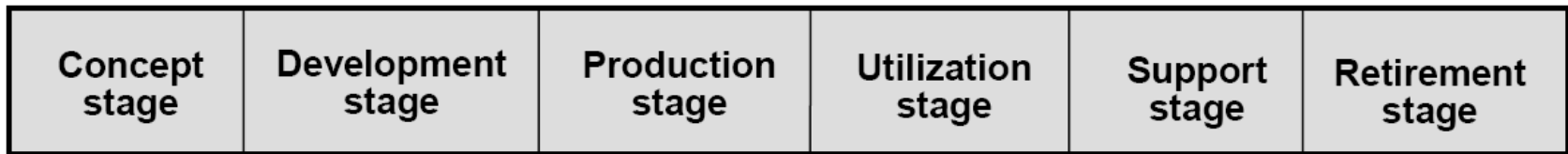

Source: ISO/IEC TR 19760, *Systems engineering — A guide for the application of ISO/IEC 15288 (System life cycle processes)*, 2003



# A Textbook Representation of Systems Engineering Stages & Phases

<b>Systems Engineering Stages</b>	<b>Concept Development</b>			<b>Engineering Development</b>			<b>Post Development</b>	
<b>Systems Engineering Phases</b>	Needs Analysis	Concept Exploration	Concept Definition	Advanced Development	Engineering Design	Integration & Evaluation	Production	Operations & Support

Source: *Systems Engineering: Principles and Practice*, Kossiakoff, A., Sweet, W. N., Seymour, S. J., and Biemer, S. M., Wiley, 2011.



# A Reference Model of the Systems Engineering Process for this Tutorial

---

- **System Needs and Opportunities Analysis**
  - Defining and validating needs, and determining feasibility
- **Concept Exploration and Evaluation**
  - Exploring and evaluating system concepts, refining required performance characteristics and required effectiveness in representative operational environments, and performing analysis of alternative concepts
- **Design and Development**
  - Designing and prototyping the system, providing for human-system integration, refining performance estimates, and production planning
- **Integration and Test & Evaluation (T&E)**
  - Integrating the system components, and testing/evaluating the system in representative environments
- **Production and Sustainment**
  - Producing and sustaining the system, including providing for reliability, availability, logistics, and training



# Comparison of System Life Cycle Models

<b>DOD 5000.02 (Hardware-Intensive Systems), 2015</b>	Material Solution Analysis	Technology Maturation & Risk Reduction		Engineering & Manufacturing Development			Production & Deployment	Operations & Support		
<b>ISO / IEC 15288, 2003</b>	Concept	Development					Production	Utilization	Support	Retirement
<b>Kossiakoff Textbook (Stages), 2011</b>	Concept Development			Engineering Development			Post-Development			
<b>Kossiakoff Textbook (Phases), 2011</b>	Needs Analysis	Concept Exploration	Concept Definition	Advanced Development	Engineering Design	Integration & Evaluation	Production	Operations & Support		
<b>This Course</b>	System Needs & Opportunities Analysis	Concept Exploration & Evaluation		Design & Development		Integration and Test & Evaluation	Production & Sustainment			

# Modeling and Simulation in System Needs and Opportunities Analysis



## Module Outline

---

- Needs vs. Opportunities for New or Improved Systems
- The U.S. Military Process for Capabilities-Based Assessment
- Commercial System Processes
- Model and Simulation Use in
  - Operational Analysis
  - Functional Analysis
  - Feasibility Determination
- Summary





## Needs vs. Opportunities for New or Improved Systems

---

- New or improved systems can be initiated
  - As the result of the need for a new or improved capability; or
  - To take advantage of an opportunity
- For military systems
  - A need can result from the emergence of a new threat
  - An opportunity can arise because of a technology breakthrough
- For commercial systems
  - A need can result from a new legal or regulatory requirement
  - An opportunity can arise from a new demand in the marketplace or financial incentives to provide an improved capability (e.g., hybrid autos)
- Models and/or simulations can be used to
  - Explore the effectiveness or utility of a new concept
  - Estimate the cost of envisioned alternatives
  - Aid in determining feasibility of a new or improved system



# The U.S. Joint Capabilities Integration and Development System (JCIDS)

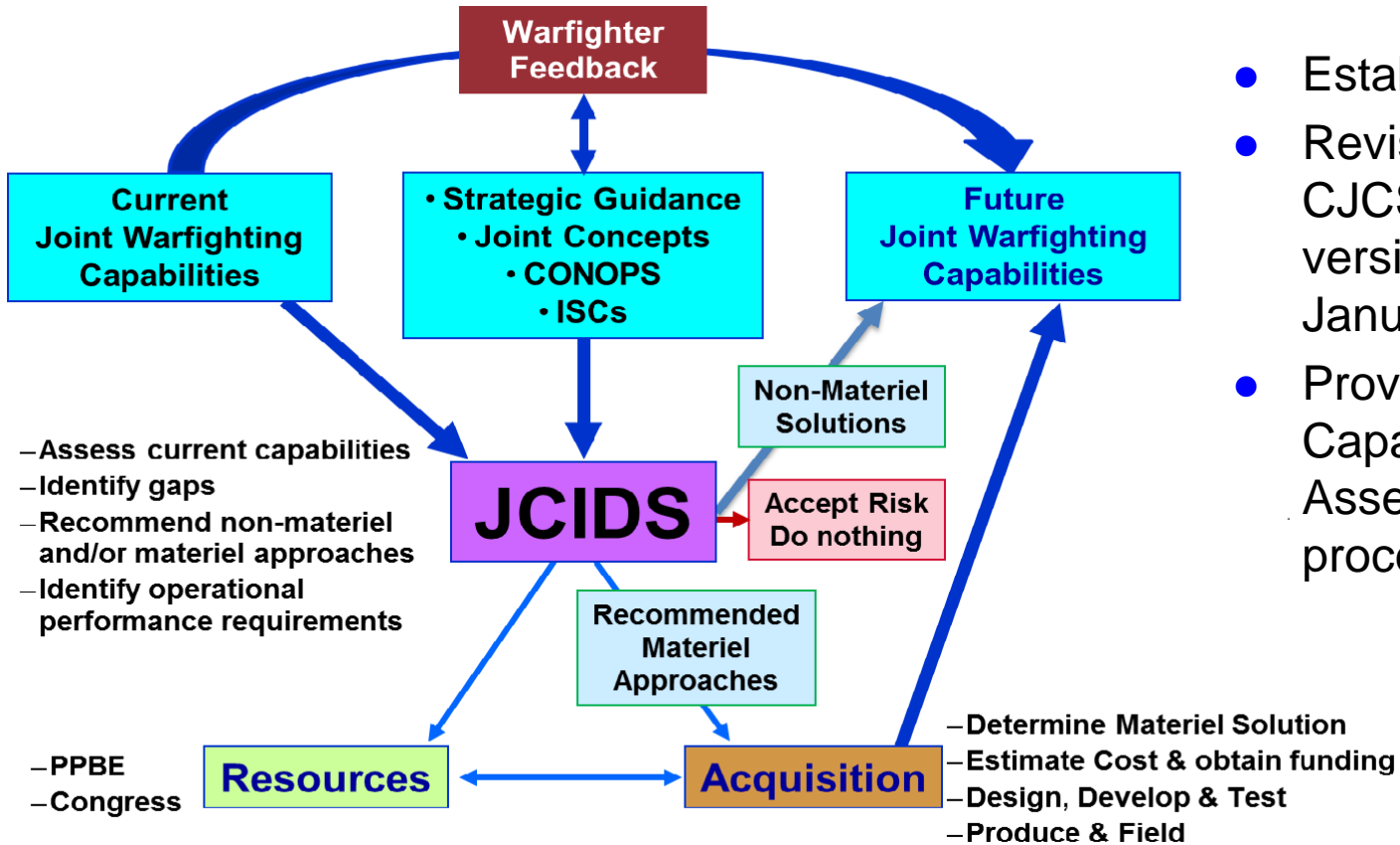

- Established in June 2003
- Revised frequently – CJCS Instruction 3170.01 version letter I issued in January 2015
- Provides for a Capabilities-Based Assessment (CBA) process

- Assess current capabilities
- Identify gaps
- Recommend non-materiel and/or materiel approaches
- Identify operational performance requirements

- PPBE
- Congress

CONOPS: Concept of Operations  
 ISC: Integrated Security Construct  
 PPBE: Planning, Programming, Budgeting and Execution

Source: Joint Capabilities Integration and Development System (JCIDS) – A Primer



# Capabilities-Based Assessment (CBA) Process in the U.S. Joint Capabilities Integration and Development System

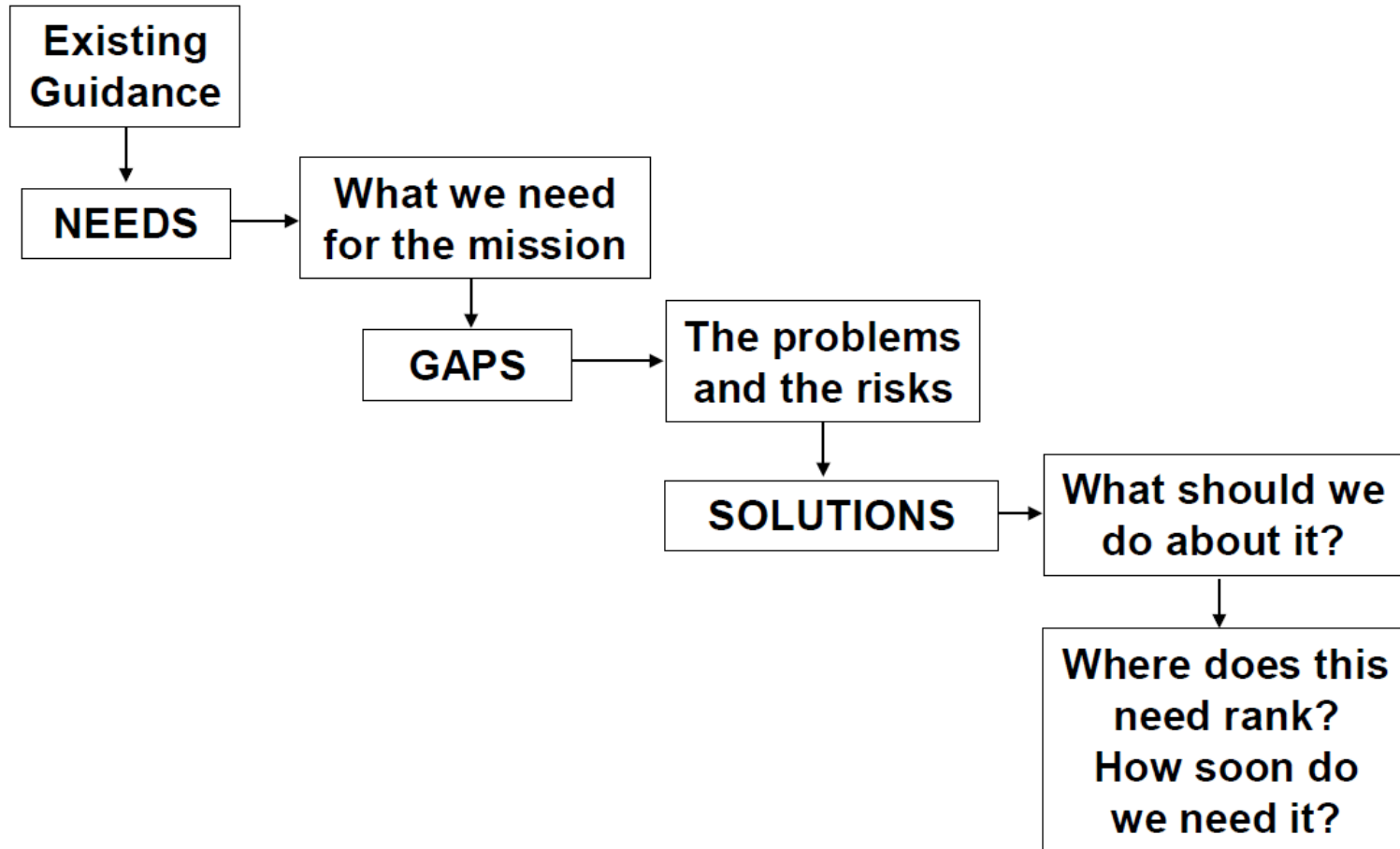

Source: Joint Capabilities Integration and Development System (JCIDS) – A Primer

# Capabilities-Based Assessment Needs Assessment Task Flow

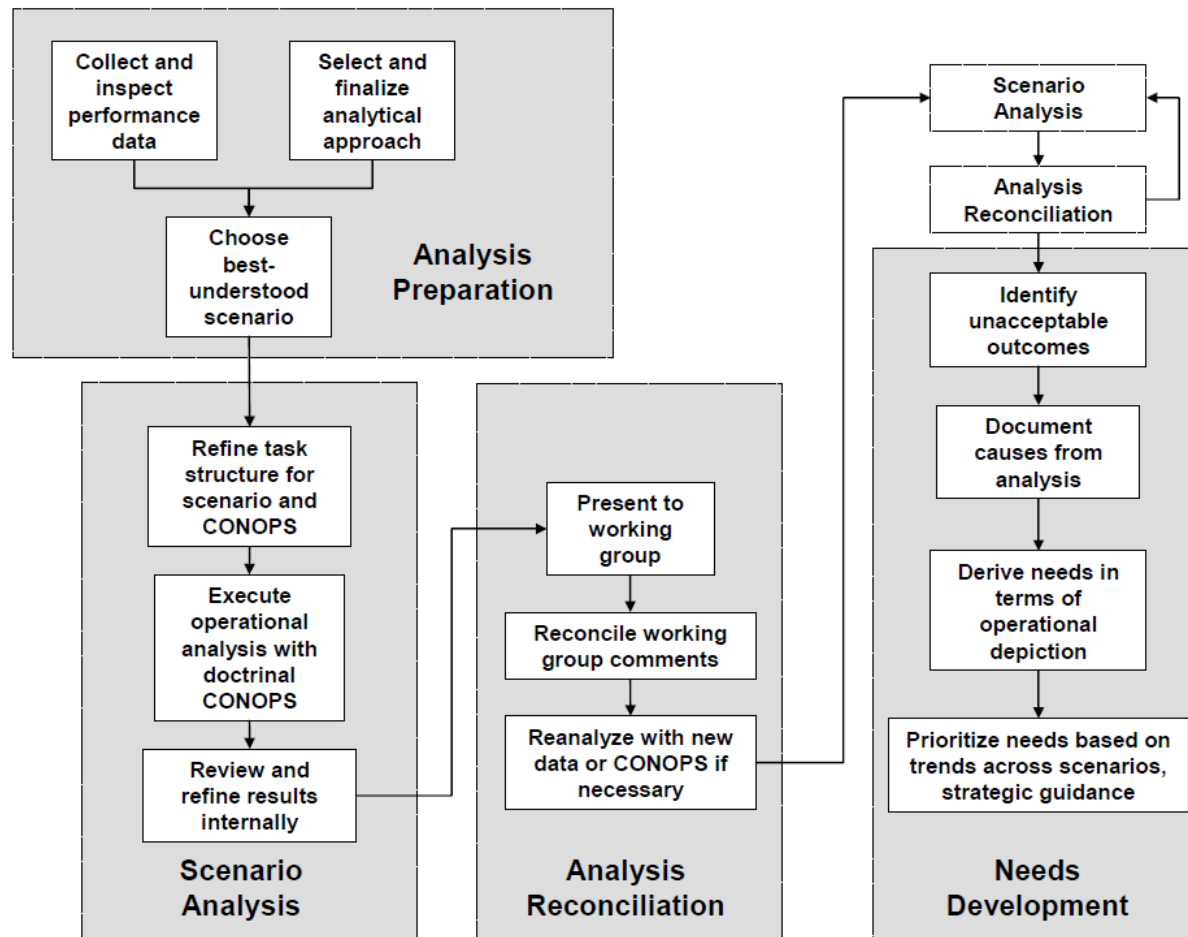

Source: Capabilities-Based Assessment (CBA) User's Guide



# Commercial Processes for Identifying and Analyzing Needs and Opportunities

- Commercial processes can vary depending on the industry and the individual company
- In general, there is a fairly continual operational analysis process, which occasionally or periodically triggers a functional analysis based on a set of operational objectives, followed by a feasibility determination resulting in operational requirements for a new or improved system

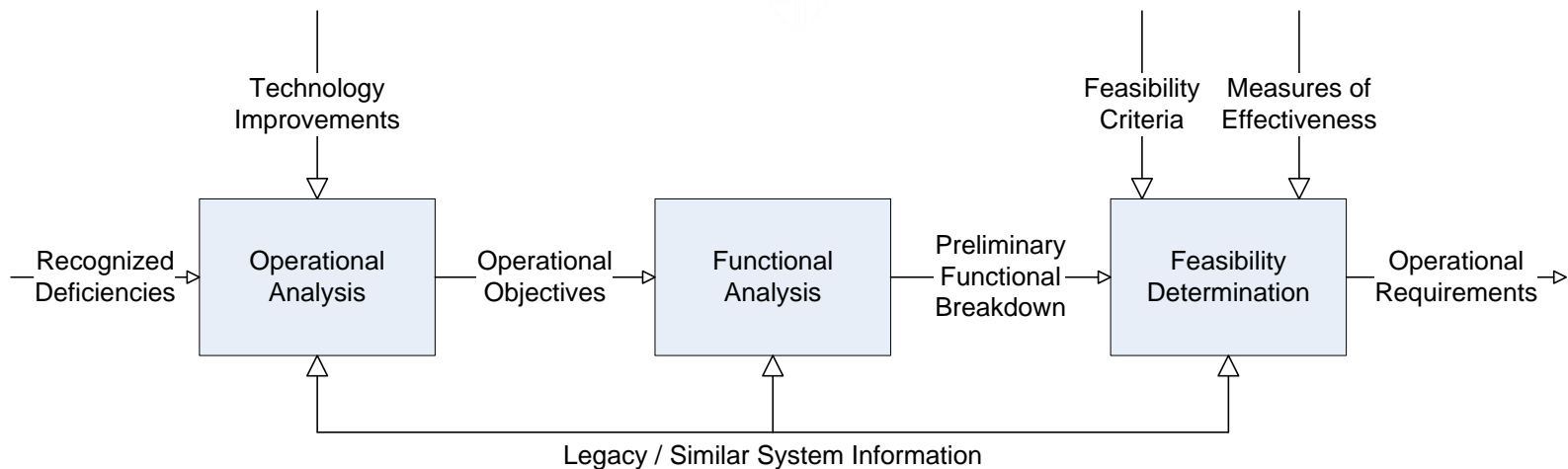

Simplified Needs and Opportunities Analysis Diagram



# Operational Analysis

## Use of Performance Simulations

---

- Simulations of (Relative) Performance
  - Although the absolute performance of a system will generally not decrease over time (and will often increase through upgrades), its *relative* performance eventually degrades
    - A new missile threat may have capabilities outside the performance envelope of an air defense system
    - Competing products may incorporate new technology (e.g., cell phone decreasing size and weight, longer battery life)
  - Performance projections for adversary or competitive systems must be continually executed to predict system obsolescence



# Operational Analysis

## Use of Total Ownership Cost and Parts Availability Models

---

- Models of Total Ownership Cost
  - Changing costs for operations and maintenance labor or consumables may impact how much a user must pay to own the product
    - At certain thresholds of the price of gasoline, ownership of vehicles with higher gasoline consumption can become unaffordable
  - Models of all ownership costs must be developed and maintained
    - See the Defense Acquisition Guidebook for the definition of total ownership cost used by the U.S. Department of Defense.
- Models of Parts Availability
  - At some point in time, parts for a given system implementation may no longer be available, at any cost
  - Models of parts availability must be developed and maintained



# Operational Analysis

## Use of Value Modeling Tools

---

- Value Modeling Tools
  - Some value attributes of systems defy quantitative engineering measurement
    - “Intelligence estimates” of the performance and fielding date of future threats are dependent on judgment of subject matter experts (SMEs)
    - “Stylishness” of new cars is in the eyes of the beholders
  - Models of value using multiple measures need to be constructed
    - Value attributes must be identified
    - Measures for collecting valid opinions and quantifying them must be devised
    - A “weighting scheme” must be applied in the model



# Operational Analysis

## Examples of Value Modeling Tools

- Quality Function Deployment
  - Developed in Japan, starting in 1966
  - Intent to transform “voice of the customer” into engineering characteristics of a product
  - Uses matrices in series of steps to derive product characteristics from customer requirements, applying weighting factors
- Analytic Hierarchy Process
  - Developed by T. L. Saaty, starting in 1980
  - Uses a hierarchy of a goal, one or more levels of criteria, and alternatives
  - Comparisons of each pair of criteria are made by subject matter experts, evaluating strength of importance to next higher level
  - Results in priority weighting to each alternative

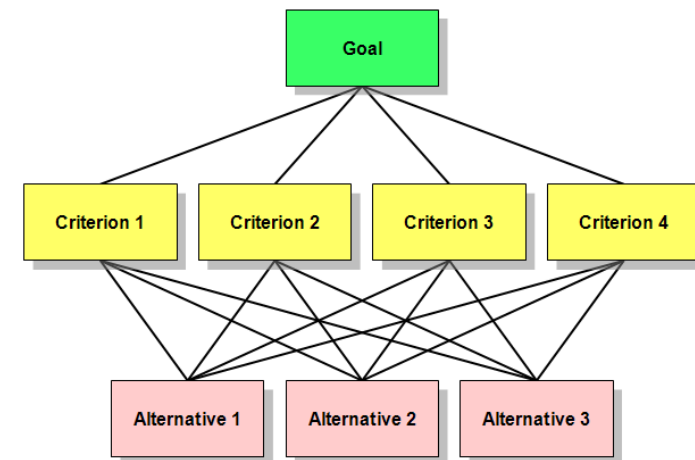
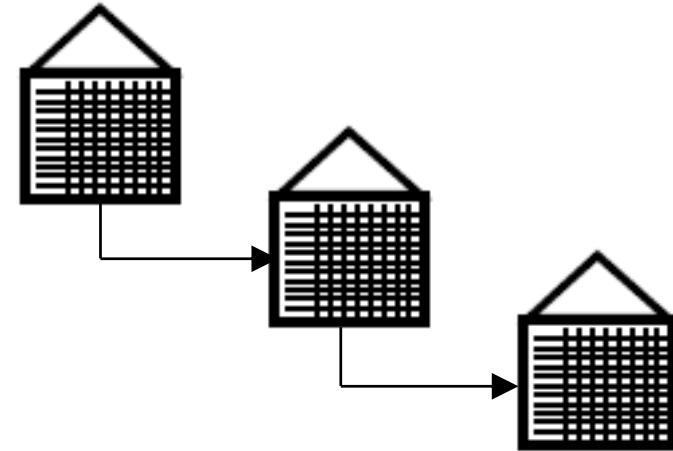

# Operational Analysis

## Use of Simulations of System Operations

- Simulation of System Operations through Games
  - Can be a structured “war game” with blue, red, white, green cells
  - Can be a “seminar” game with subject matter experts in various fields working collaboratively
  - Can be used to explore concepts of operations for proposed systems
  - The term “serious games” has come into vogue to describe these



### Seminar Game Example:

- *How would I use the existing system in this scenario?*
- *What technology improvements could be made?*
- *If I had a system with this capability, what would I do now in this situation?*



## Model and Simulation Use in Functional Analysis

---

- Functional analysis needs to translate operational system objectives into system functions
  - Essentially, a feasible concept must be able to be “envisioned”
  - In a need-driven process, some system functions might be relatively well-known from legacy systems
- Deriving a functional structure contains elements of art / architecting
- Modeling tools can be used to develop a system functional breakdown
  - Can start with a relatively simple block diagram (e.g., Microsoft Visio or PowerPoint could be used to generate a top-level “model” of a system)
  - More formal notations can be used to ensure inputs and outputs are properly considered (e.g., IDEF0, Unified Modeling Language (UML), or Systems Modeling Language (SysML) diagrams)



# Feasibility Determination

## Use of System Operational Effectiveness Simulations

---

- Simulations of System Operational Effectiveness – Input Needs
  - Performance estimates for an envisioned system implementation, at a less-detailed level, such as
    - Probability of detection as a function of target cross-section and range (in various environments) for a radar system
    - Miles per gallon as a function of fuel octane, temperature, and pressure for an automobile
  - Similar performance estimates for
    - Collaborative/cooperative/friendly systems
    - Adversary/threat/competitive systems
  - Concept of operations for the envisioned system
  - Representations of the natural environment (land, sea, air, and/or space), or the man-made environment, often time-varying
  - Usage scenarios for the envisioned system, including such things as geographic location, time of year, numbers of friendly/threat assets



# Feasibility Determination

## Use of Total Ownership Cost and Sustainability Models

---

- Models of Total Ownership Cost
  - Similar to those used during operational analysis
- Models and Simulations of Sustainability
  - Reliability models (at a relatively high level, unless data on similar legacy system components are available)
  - Availability models (percentage of time the system will be ready when called upon)
  - Maintainability models (e.g., time to repair)
  - Logistics support simulations

## Illustration of Simulation Use in Feasibility Determination

- Campaign-level Simulations
  - Use Measures of Performance (MoPs) of systems as inputs
  - Simulate system operation in a computer-based operational environment
  - Produce Measures of Effectiveness (MoEs) as outputs
  - Can be used to answer “so what” questions for proposed new systems

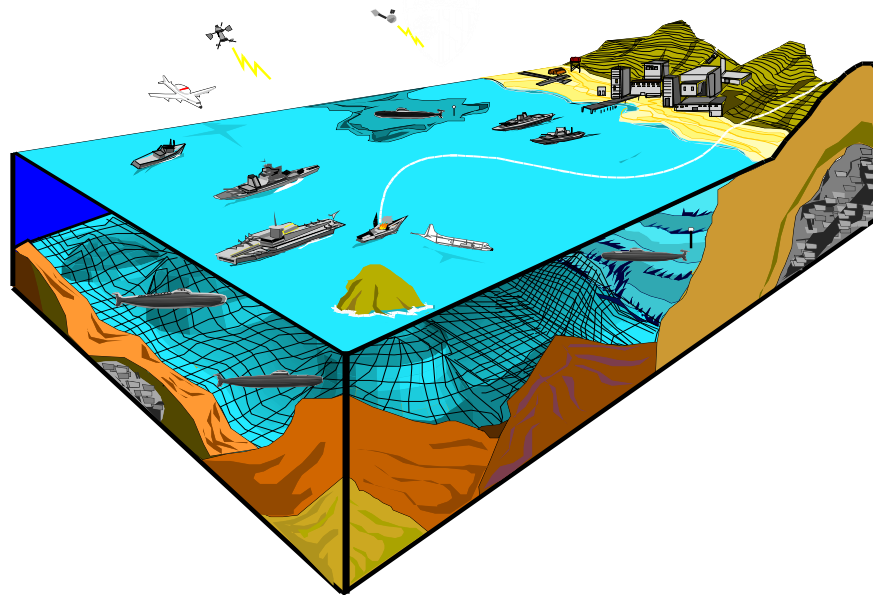



## Module Summary

---

- New or improved systems can be initiated as the result of the need for a new or improved capability, or to take advantage of an opportunity
- For both military capabilities and commercial systems, there are somewhat similar approaches to needs/opportunities analysis, but using different terminology
- Value modeling tools are often useful during operational analysis to help quantify SME opinions
- Formal modeling notations and tools are useful in adding rigor to system functional breakdowns
- Operational effectiveness simulations are important in performing
  - Ongoing operational analysis to determine operational objectives for new or improved systems
  - Analysis of envisioned system implementations to determine feasibility
- Cost models must consider the total ownership cost of systems, not just the development cost
- Sustainability (reliability, availability, maintainability, logistics) models and simulations are also of significant importance in operational analysis and feasibility determination

# Modeling and Simulation in Concept Exploration and Evaluation





# Module Objective and Outline

---

Module Objective: To describe the use of modeling and simulation in the concept exploration and evaluation phase of the systems engineering process.

## Module Outline

- Scope of Concept Exploration and Evaluation
- A Simplified Process Model for Concept Exploration and Evaluation
- Effectiveness Simulations
  - Components of Effectiveness Simulations
- Analyses of Alternatives
  - System Effectiveness Simulation
  - Cost Modeling
- Ensuring a “Level Playing Field”
- Summary



## Scope of Concept Exploration

---

- Involves translating the operational requirements for the system into engineering-oriented *performance requirements* for the system
  - interpret, but do not replace, the operational requirements
- Several alternative candidate system concepts are envisioned, and their performance characteristics established
- Can sometimes be relatively limited, to only particular functions or portions of a legacy system
- For new systems, a more creative, non-prescriptive method is indicated that is akin to *systems architecting*



## Scope of Concept Evaluation

---

- Involves taking the alternative concepts produced during concept exploration, defining them even further, and evaluating them
- May be done by a single organization or, in the case of a major system development by separate organizations in a competitive environment, with an independent organization evaluating those concepts
- Results in a selected system concept and a set of system functional specifications suitable to enter development



# A Simplified Process Model for Concept Exploration and Evaluation

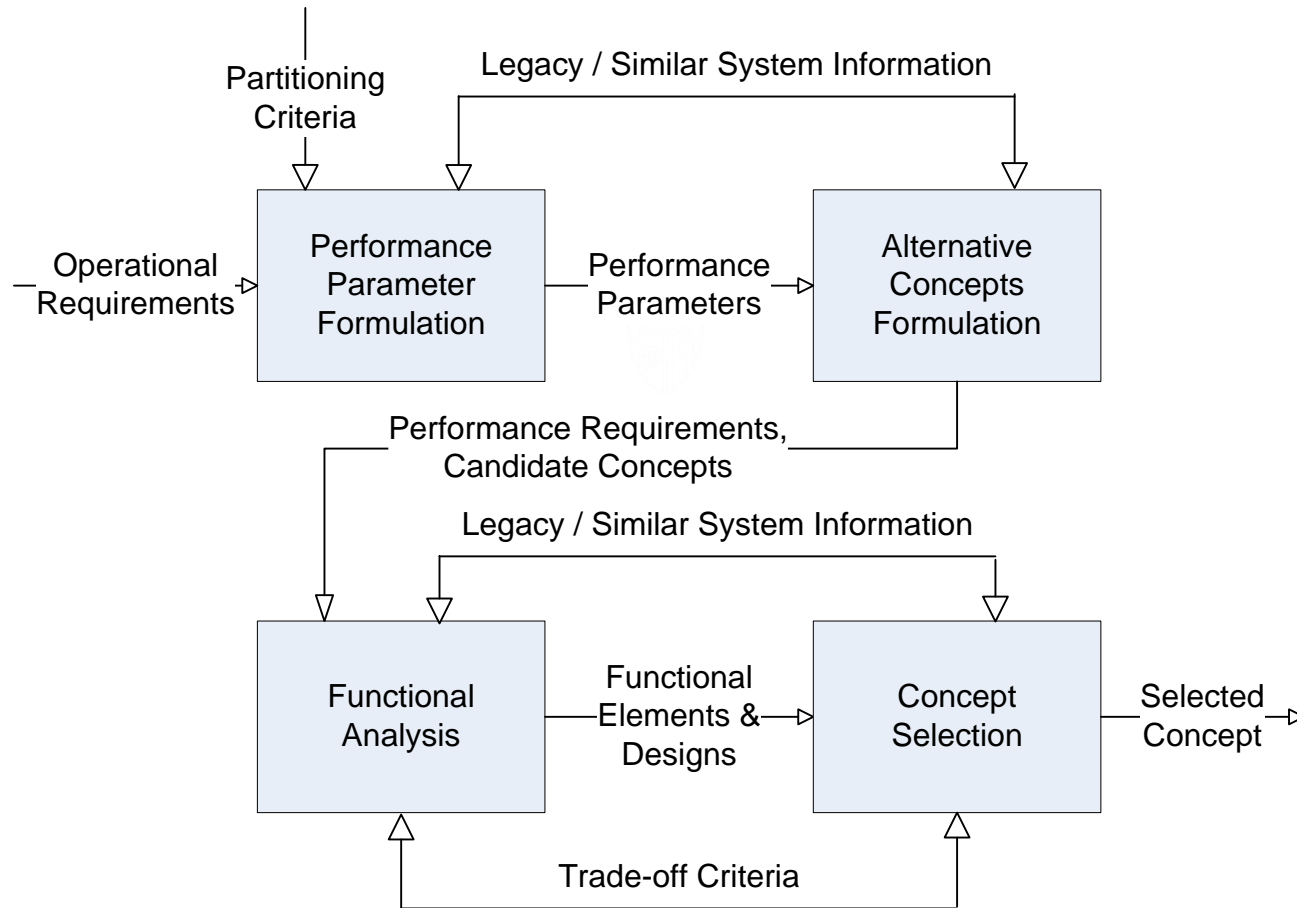



# Requirements Modeling and the SysML Requirement Diagram

---

- System requirements have traditionally been defined only in text specifications, often leading to ambiguity.
- The Systems Modeling Language (SysML) introduced a Requirement Diagram, in an effort to model requirements.
- The SysML Requirement Diagram
  - Includes an id and text properties
  - Provides for a requirements hierarchy that describes requirements contained in a specification
  - Provides for relationships among requirements, including Containment, DeriveReq, Satisfy, Verify, Refine, Trace, Copy
  - Allows user-defined properties (e.g., verification method)
  - Allows user-defined requirements categories (e.g., functional, interface, performance)



# Requirements Modeling

## A Simple Example of a SysML Requirement Diagram

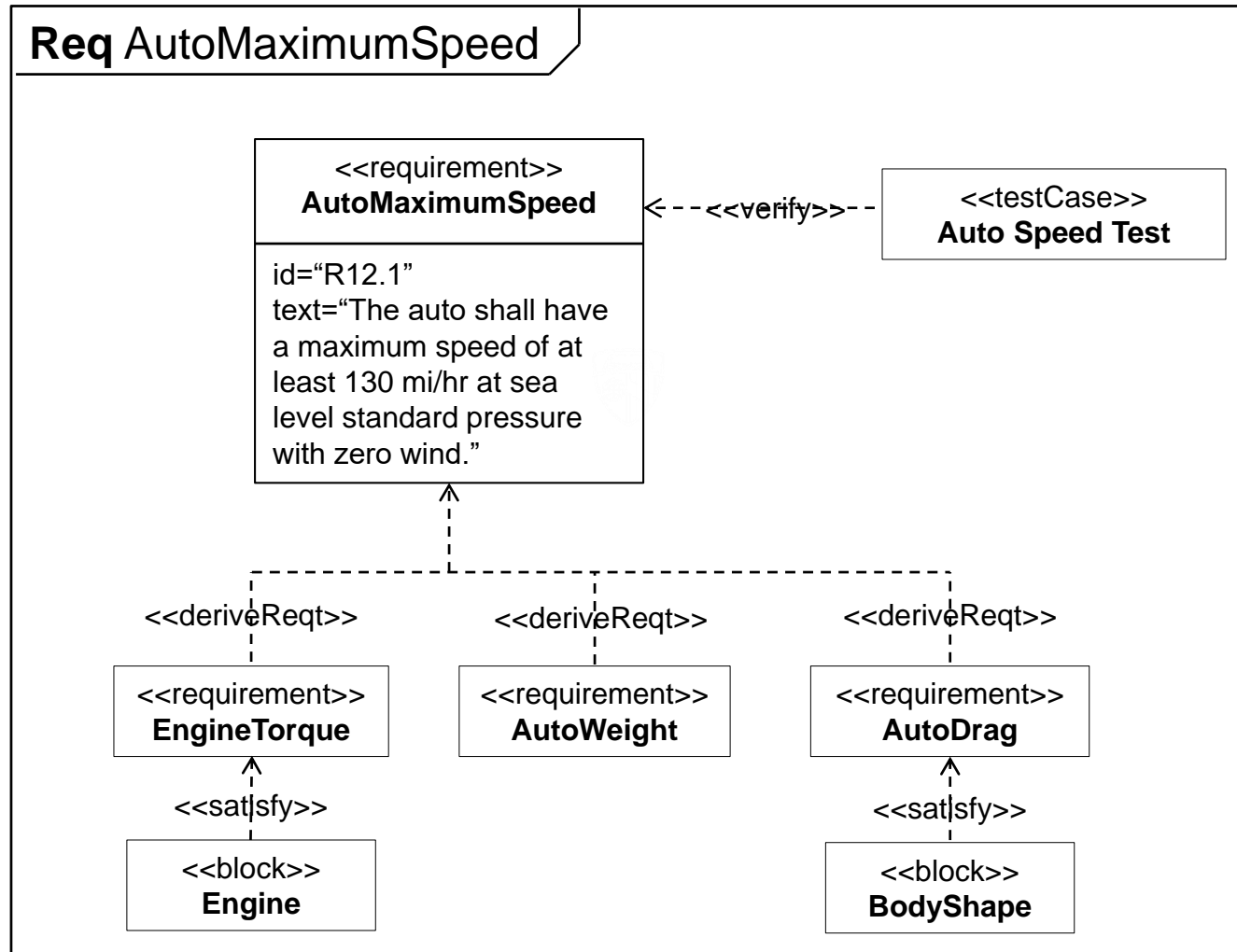



## Use of Legacy / Similar System Information and M&S Tools

---

- Reuse of models/simulations is usually cost-effective
  - Models/simulations usually require some adaptation
  - Need subject matter experts & M&S professionals familiar with tools
  - Less experienced teams can make use of M&S repositories / registries to assist in discovery process
- Issues to be aware of
  - Lack of awareness of existing M&S tools
  - “Not invented here” (NIH) syndrome
  - Force-fit of familiar tools (“we’ve always used this one”)
- Best to do selection based on objective set of requirements / criteria
- Availability of authoritative data can be an issue
  - Authoritative data on military threat systems may be hard to obtain
  - Authoritative data on “friendly” systems may require time-consuming release approval



# An Overview of Effectiveness Simulations

---

- Are typically at the “mission level” of the military simulation pyramid
- Generally use parameterized system performance data generated by performance simulations
- Major components of effectiveness simulations
  - The system representation (in performance terms)
  - The system’s concept of operations
  - The representation of adversary, cooperative, and neutral systems
  - The representation of the natural and man-made environment
  - The scenario
- Supporting elements of effectiveness simulations
  - User interface
  - Data input mechanisms
  - Results output mechanisms





# Effectiveness Simulations

## Representing the System

---

- During concept exploration and evaluation
  - Only early estimates of system performance may be available
  - Systems based on legacy components typically have more credible representations than those based on new technology
- Can sometimes use effectiveness simulations for screening
  - “If we could build a system with this performance, would it make a difference?”
  - Does achieving desired performance require unrealistic operational conditions?
- System performance typically represented parametrically
  - Using equations
  - Using tables of two or more dimensions

# Effectiveness Simulations

## Concept of Operations

- Must represent how the system is employed in practice
  - Concept of operations (CONOPS) can affect system performance
- Examples of CONOPS effects on performance
  - Submarine towed array system performance is affected by submarine maneuvers
  - Radar systems may direct more energy into certain azimuth bands based on returned signals
  - Airborne system flight performance differs in formation flying as compared to solo flights

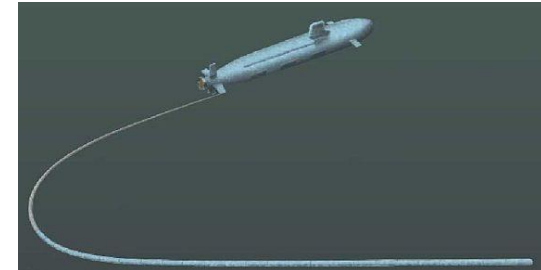

# Effectiveness Simulations

## Adversary, Cooperative, and Neutral Systems

- Virtually every system, whether commercial or military, will need to interact with other systems
- Types of interacting systems
  - Adversary/threat (“red”) systems
    - Military example: Enemy tanks on a battlefield
  - Cooperative/friendly (“blue”) systems
    - Military example: Fighter aircraft in a squadron
    - Commercial example: GPS system and driverless car steering system
  - Neutral (“green”) systems
    - Military example: Civilian vehicles in an urban combat environment
    - Commercial example: Other cars in traffic





# Effectiveness Simulations

## Levels of Detail in System Representations

---

- Level of detail at which adversary, cooperative, and neutral systems need to be represented depends on nature of potential interactions with system being studied
  - If neutral systems are only “clutter,” can be modeled simply
  - Some cooperative systems may only need to be modeled as a source of communication messages, with a probability of successful delivery
  - But some adversary systems need detail commensurate with system being studied (e.g., threat aircraft in a “dogfight” scenario)



# Effectiveness Simulations

## Effects of the Natural and Man-Made Environment

---

- The effectiveness of almost every system is dependent on the effects of the natural and the man-made environments during operation.
  - Some effects are well known and can be tolerated (e.g., Global Positioning System (GPS) reception in middle of two-mile tunnel)
  - Some effects cannot be tolerated (e.g., auto engine overheating in Death Valley)
- Environmental conditions are typically more important for military (and law enforcement) systems, which need to operate with high reliability in more stressful environments than commercial systems.
  - Dust storms for ground vehicles, jamming environments for communication systems, and supersonic airflows for aircraft
  - In some cases, degradation of performance can be tolerated, but needs to be quantified (e.g., sonar performance)
- Effectiveness simulations must model environmental conditions with fidelity commensurate with their effects on the system.

# Effectiveness Simulations

## Some Elements of the Natural Environment

- Atmospheric characteristics
  - Temperature, pressure, humidity, wind speed – for airborne systems and electromagnetic propagation
- Ground terrain characteristics
  - Height vs. position, soil properties – for ground-based systems and line-of-sight calculations
- Ocean characteristics
  - Depth, sound velocity profile, wave height – for maritime systems
- Space characteristics
  - Solar flares, sun spots – for satellite reliability / availability and electromagnetic propagation.

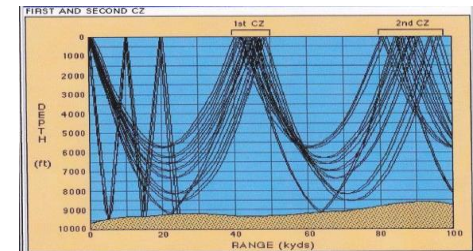
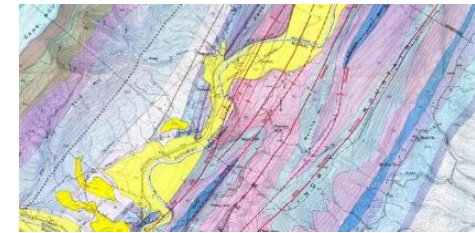



# Effectiveness Simulations

## Some Elements of the Man-Made Environment

- Building sizes and shapes
  - For line-of-sight calculations and urban wind velocity / contaminant propagation
- Road networks
  - For transportation modeling
- Electromagnetic emissions
  - For electromagnetic interference calculations

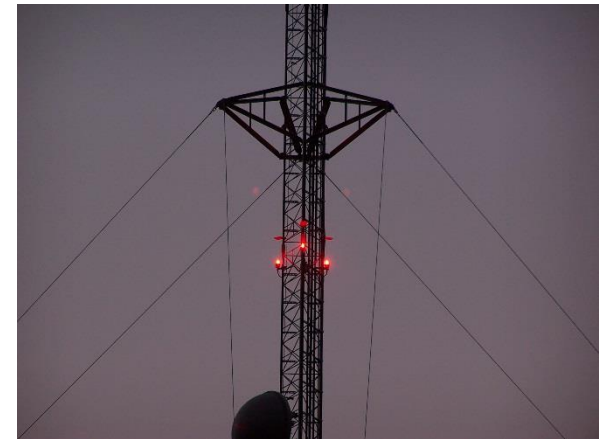
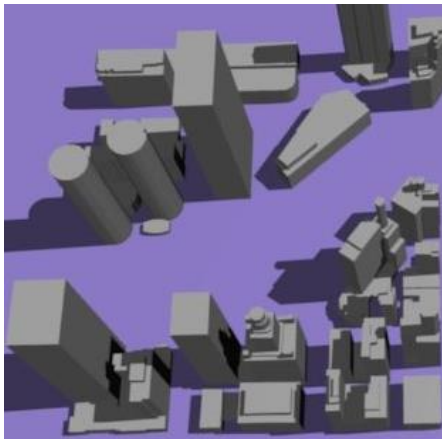



# Effectiveness Simulations Scenarios

---

- Scenarios often start out as high-level text descriptions
  - But must be quantified to be used in effectiveness simulations
- Scenarios for a military simulation will typically include
  - The numbers and types of each adversary, cooperative, and neutral system involved
  - System concepts of operation, and the way in which entities move (either scripted, or in some reactive way)
  - Location and extent of the “play box(es)”
  - Instantiations of the natural and/or man-made environment, sometimes in great detail (e.g., Digital Terrain Elevation Data (DTED) terrain files)
  - A time of year (important for choosing appropriate atmospheric and maritime natural environment data sets)
  - A duration, which could range from as little as seconds for a missile intercept to days or weeks for an extended ground battle





# Use of Interoperable Simulations

---

- Research and development started in the training community with the DARPA SIMNET program in the late 1980s.
- In the early 1990s, interoperable simulation standards, allowing a set of simulations to interact during execution (often referred to as a *federation*), began to emerge.
- Use can be beneficial when there are existing credible standalone simulations of specific systems (or missions), but a simulation must be performed that involves several such systems (or missions).
- Examples of interoperable simulation standards:
  - Distributed Interactive Simulation (DIS)
    - Designed for real-time operation; no guaranteed message delivery or ordering
  - High Level Architecture (HLA)
    - Includes time management, five other services
  - Test and Training Enabling Architecture (TENA)
    - Designed for real-time operation only; DoD-centric business model



# Analyses of Alternatives

- An Analysis of Alternatives (AoA) is an analytical comparison of the operational effectiveness, suitability, and life-cycle cost (or total ownership cost, if applicable) of alternatives that satisfy established capability needs.
- Involves performing
  - Selection of alternatives
  - Determination of effectiveness measures
  - Effectiveness analysis
  - Cost analysis
  - Cost-effectiveness comparisons

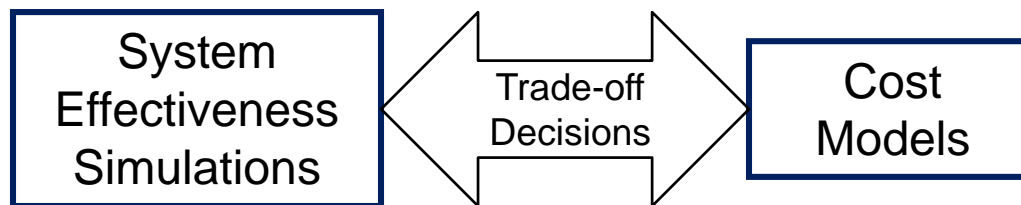



# Analyses of Alternatives System Effectiveness Simulation

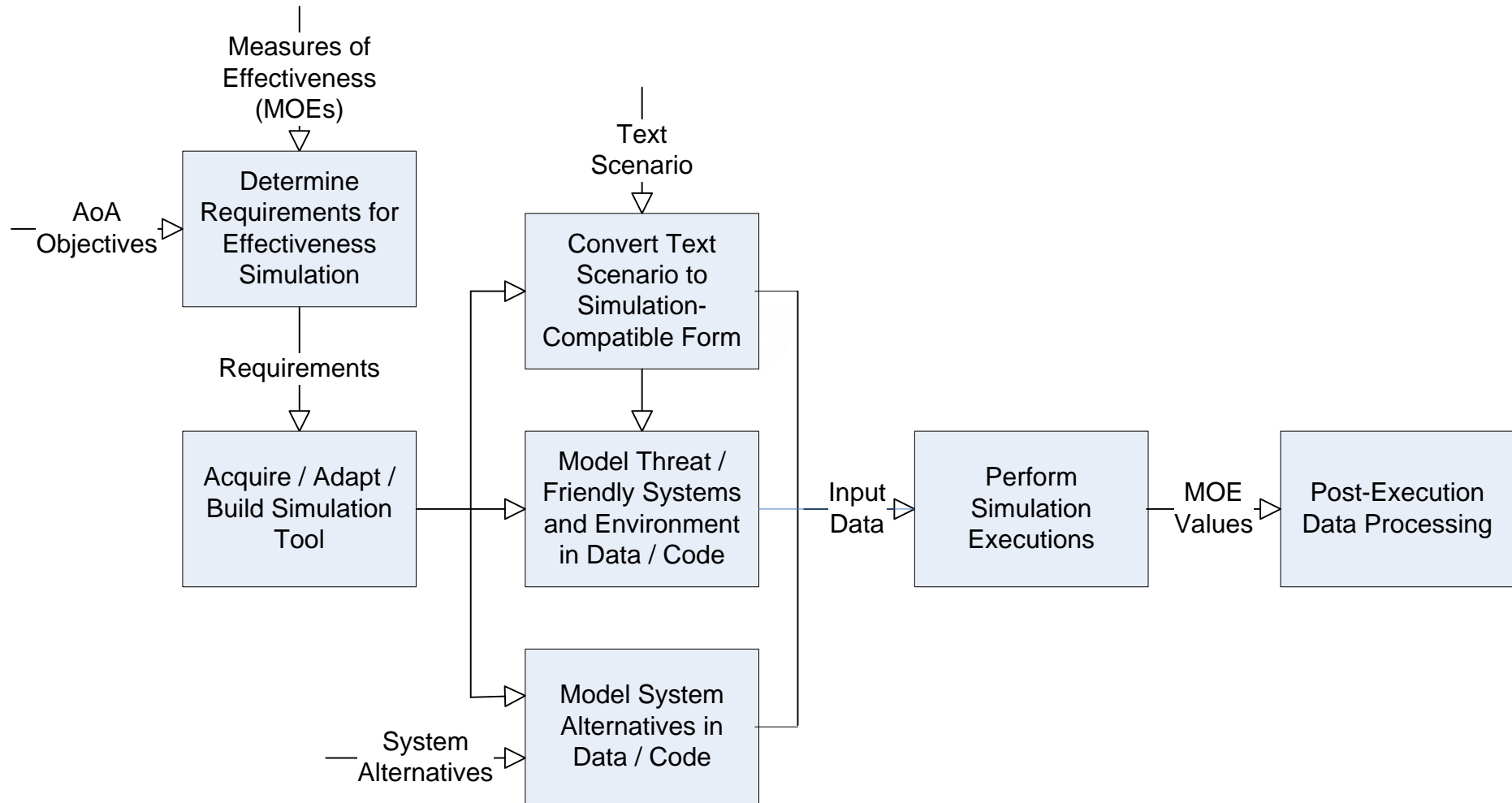



# Analyses of Alternatives

## Cost Modeling

---

- Need to consider all elements of system cost:
  - Development cost
  - Production cost
  - Support (repairs, logistics, training, etc.) cost
  - Disposal cost
- Development cost modeling
  - Need to assess development risk, cost uncertainty
- Production cost modeling
  - Need to account for manufacturing systems development cost, number of units
- Support cost modeling
  - Support cost is usually the largest element of total cost (~50%)
  - Need to consider life of system, number of operators, logistics system
- Disposal cost modeling
  - Often neglected; need to consider hazardous materials



# Analyses of Alternatives

## Ensuring a “Level Playing Field”

---

- When comparing system alternatives, need to ensure that each system is modeled “fairly” with respect to other systems
- Need to model systems themselves at similar levels of resolution
- Need to take into account key concepts of operation for each system
  - For example, energy management for some radar systems
- Need to model aspects of environment at appropriate levels of detail
  - For example, line of sight for ground-based weapon systems



# Module Summary

---

- A number of alternative system concepts are devised and evaluated during the Concept Exploration and Evaluation phase.
- Reuse of existing models and system effectiveness simulation tools, and of data on legacy systems, can often be useful in this phase.
- Effectiveness simulations include
  - The system representation (in performance terms)
  - The system's concept of operations
  - Representations of adversary, cooperative, and neutral systems
  - Representations of the natural and man-made environment
  - Scenarios of system use.
- An Analysis of Alternatives (AoA) is typically performed for major defense systems, and employs both system effectiveness simulations and cost models.
- When used to compare the effectiveness of alternative systems, simulations must ensure a “level playing field” for all of the systems.

# Modeling and Simulation in Design and Development



## Module Outline

---

- Scope of Design and Development
- A Simplified Process Model for Design and Development
- Distinguishing Characteristics of Models and Simulations Used in Design and Development
- Range of Engineering Disciplines Involved in M&S Tools Used in System Design and Development
- Typical Applications and Example Models and Simulations for Design and Development, in Various Disciplines
- Methods of Integrating Engineering-Level Simulations
- Time Management in Simulations Interacting at Run-Time
- Summary





# Scope of Design and Development

---

- The design and development phase of systems engineering, as discussed in this tutorial, refers to the combination of the following in *Systems Engineering: Principles and Practice* [1]:
  - Advanced Development
  - Engineering Design
- Design and development takes a system concept as input, and transforms it into a set of realized system components that are ready for system integration and testing

Source: (1) Kossiakoff, A., Sweet, W. N., Seymour, S. J., and Biemer, S. N., *Systems Engineering: Principles and Practice, Second Edition*, John Wiley & Sons, Inc., Hoboken, N. J. (2011).



# A Simplified Process Model for Design and Development

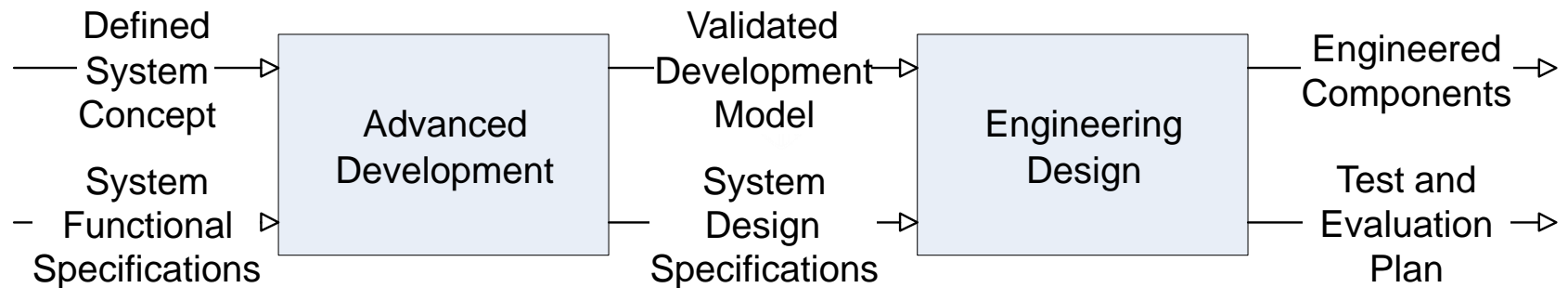



# Distinguishing Characteristics of Models and Simulations Used in Design and Development

---

- Using the four-level military simulation pyramid as a reference, most of the simulations used during Design and Development fall within the engineering level.
  - They usually model individual components of the system.
  - They often execute slower (or much slower) than real time.
  - In many cases, they need to interface with one another to represent a subsystem or the system as a whole.
  - They produce data useful as input for engagement-level simulations.
- Whereas the earlier phases of the systems engineering process may utilize a relatively small number of models and simulations, in Design and Development, there is typically a large number of rather diverse models and simulations that are employed.
- Just as a systems engineer typically needs broad expertise to “ask the right questions” across a range of engineering disciplines during Design and Development, a systems engineer responsible for M&S needs to have a broad view of M&S tools that can be applied in a range of disciplines during this phase.



# Range of Engineering Disciplines Involved in M&S Tools Used in System Design and Development

- Structural mechanics/dynamics
- Fluid dynamics
- Thermal analysis
- Propulsion
- Materials engineering
- Printed circuit design
- Electrical power system design
- Guidance, navigation and control
- Communication systems engineering
- Computer network engineering
- Cyber security
- Software engineering
- Acoustic propagation
- Electromagnetic propagation
- Optical systems engineering
- Manufacturing process modeling
- Traffic flow
- Human-systems integration
- Crowd dynamics
- Human behavior

Example M&S tools for many of these areas are cited in the next section. Mention of a specific M&S tool does not imply endorsement.

# Structural Mechanics/Dynamics Simulations

- Typical Applications:
  - Finite element analysis
  - Dynamic load analysis
- Examples:
  - NASTRAN (originally from “NASA Structural Analysis” in the late 1960s)
  - LS-DYNA® (Livermore Software Technology Corp.)

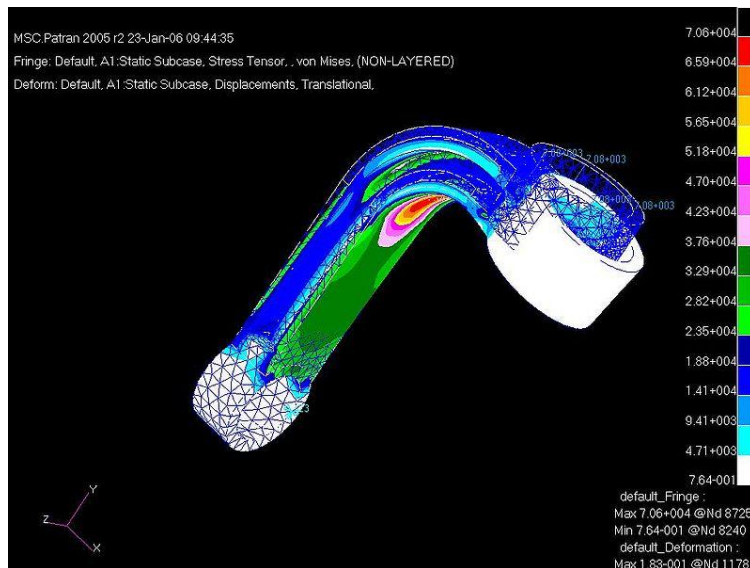

MSC Nastran result (source: Wikipedia)

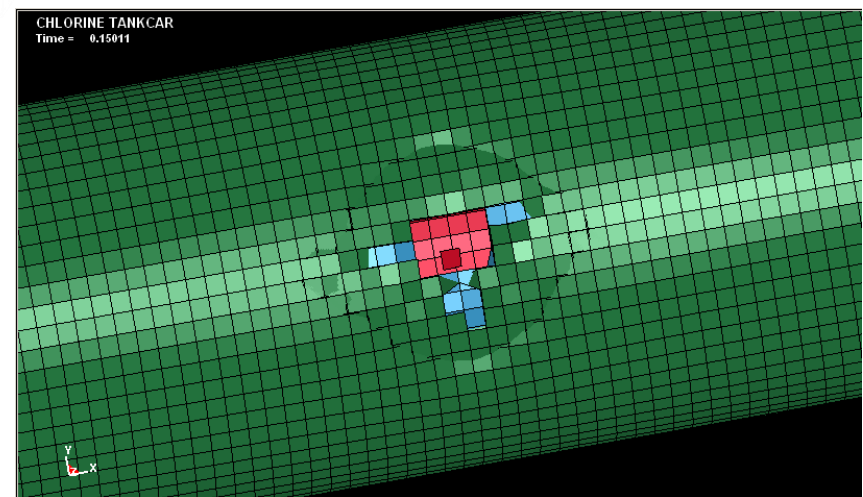

LS-DYNA result of explosive rupture of railcar  
(source: Florida A&M University)

# Fluid Dynamics Simulations

- Typical Applications:
  - Air flow around solid shapes
  - Hydrodynamic analysis
- Examples:
  - ANSYS ([www.ansys.com](http://www.ansys.com))
  - HYB-3D (University of Alabama at Birmingham)

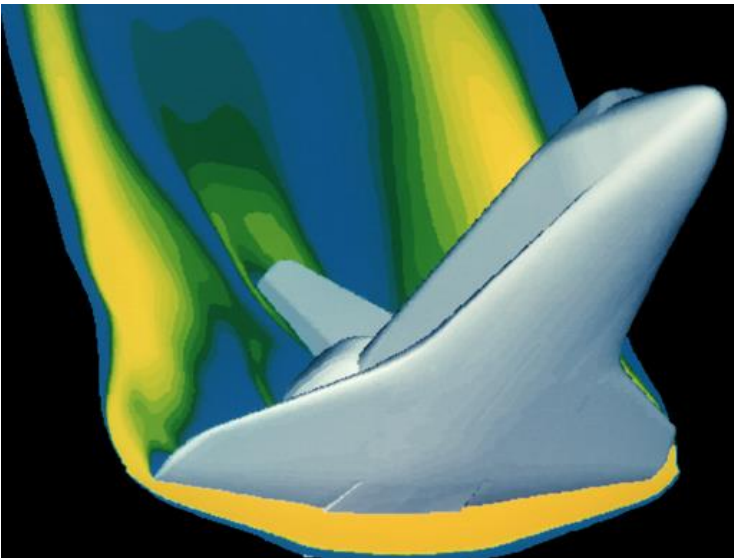

Flow around the Space Shuttle (source: NASA)

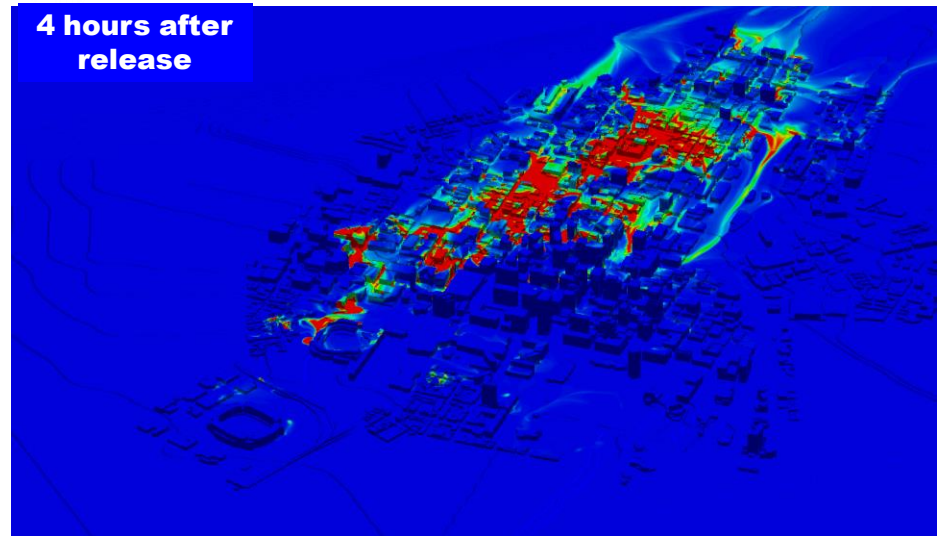

Chlorine spill dispersion in an urban area (source: UAB)



# Materials Engineering Models

---

- Typical Application:
  - Predicting fatigue crack growth in structures
- Example:
  - AFGROW (Air Force Growth)



Example of crankshaft fatigue (source: Wikipedia)

# Printed Circuit Design Simulations

- Typical Applications:
  - Simulation of electrical circuit board behavior during design
- Examples:
  - SPICE (Simulation Program with Integrated Circuit Emphasis)
    - 1973 Cal Berkeley, open source, spawned commercial variants
  - Logisim (digital circuits only, open source, student audience)

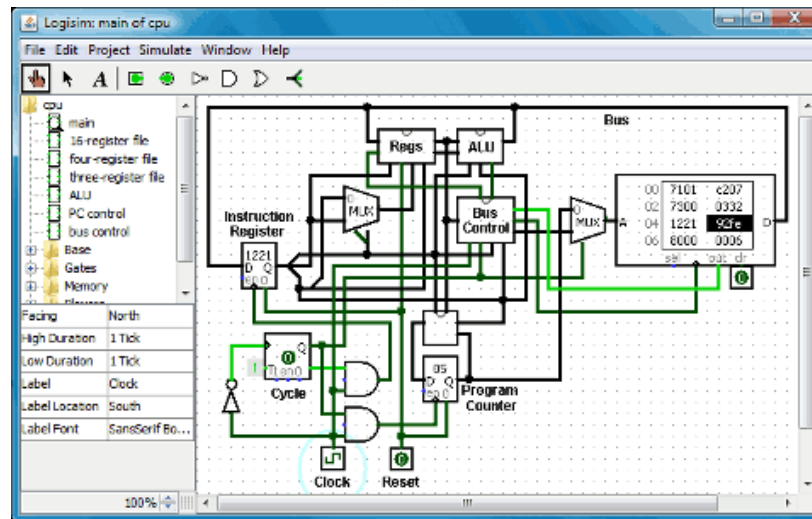

Screen shot of Logisim 2.3.4, released April 1, 2010 (source: Hendrix College web site)





## Electrical Power System Design Simulations

---

- Typical Applications:
  - Simulation of power systems for buildings and communities
  - Simulation of a regional or national electric power grid
- Examples:
  - eMEGAsim – OPAL-RT Technologies
  - RTDS® (Real Time Digital Simulator) – RTDS Technologies



# Computer Network Engineering Simulations

---

- Typical Applications:
  - Design and performance evaluation of computer networks
  - Simulation of natural and man-made network disruptions
- Examples:
  - OPNET Modeler
  - Joint Communication Simulation System (JCSS) [formerly NETWARS]

# Acoustic Propagation Models

- Typical Applications:
  - Determination of detection ranges for underwater sound sources
  - Determination of sound speed based on environmental features
- Examples:
  - Automated Signal-Excess Prediction System (ASEPS) Transmission Loss (ASTRAL)
  - Modular Ocean Data Assimilation System (MODAS)

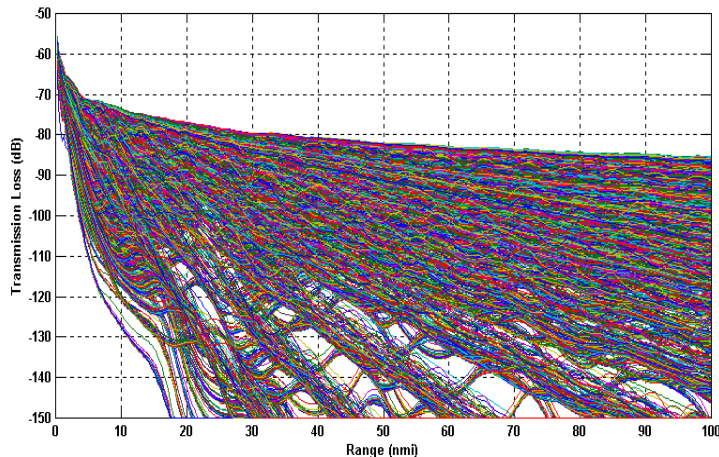

ASTRAL transmission loss curves (source: Biondo & Mandelberg – MIV project)

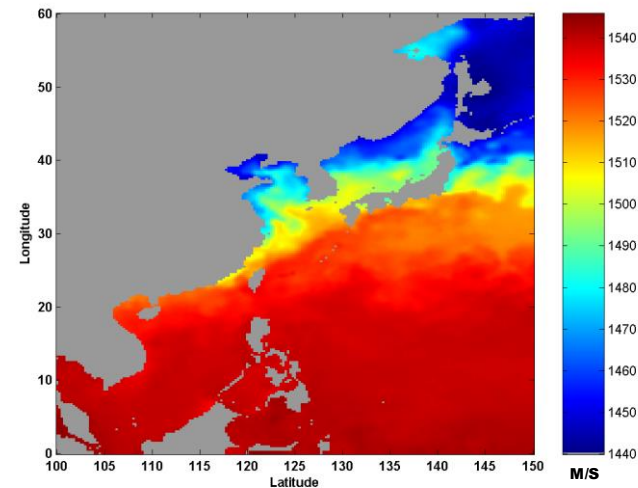

MODAS surface sound speed (source: Biondo, Mandelberg et al – JWARS-MIV project)

# Electromagnetic Propagation Models

- Typical Application:
  - Determination of atmospheric detection ranges for electromagnetic sources
- Example:
  - Tropospheric Electromagnetic Parabolic Equation Routine (TEMPER)

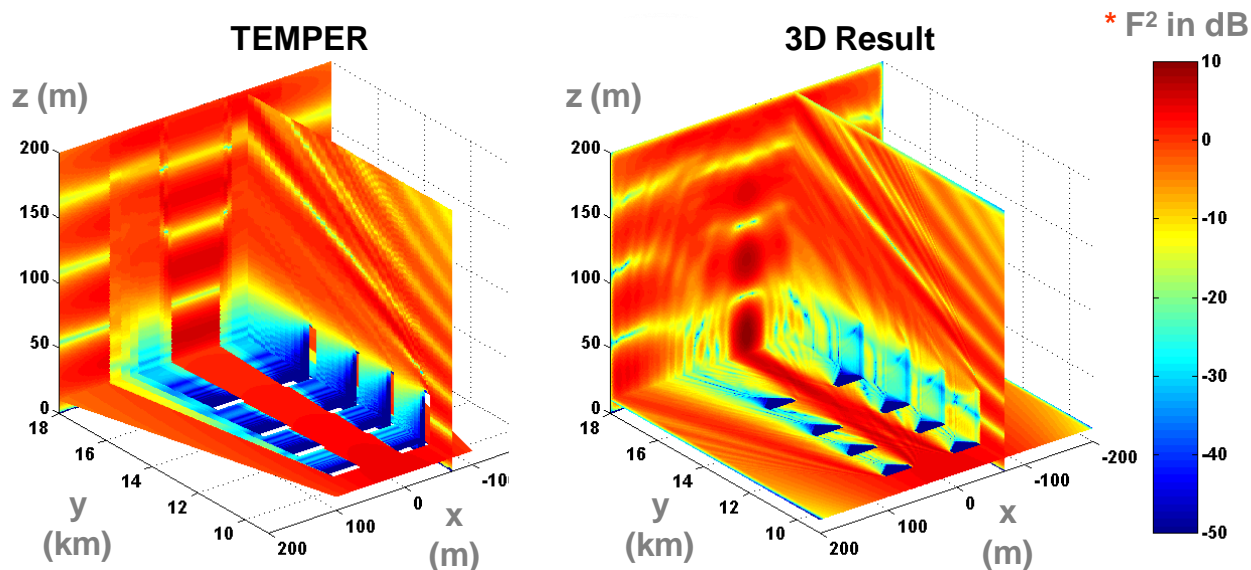

\* Propagation factor "F"  $\equiv |E / E_0|$  where  $E_0$  is free-space field

Source: Awadallah, et al, Radar Propagation in 3D Environments, 2004

# Manufacturing Process Models

- Typical Applications:
  - Determining and optimizing production rates
  - Determining bottlenecks in planned production lines
- Examples:
  - ExtendSim
  - Arena

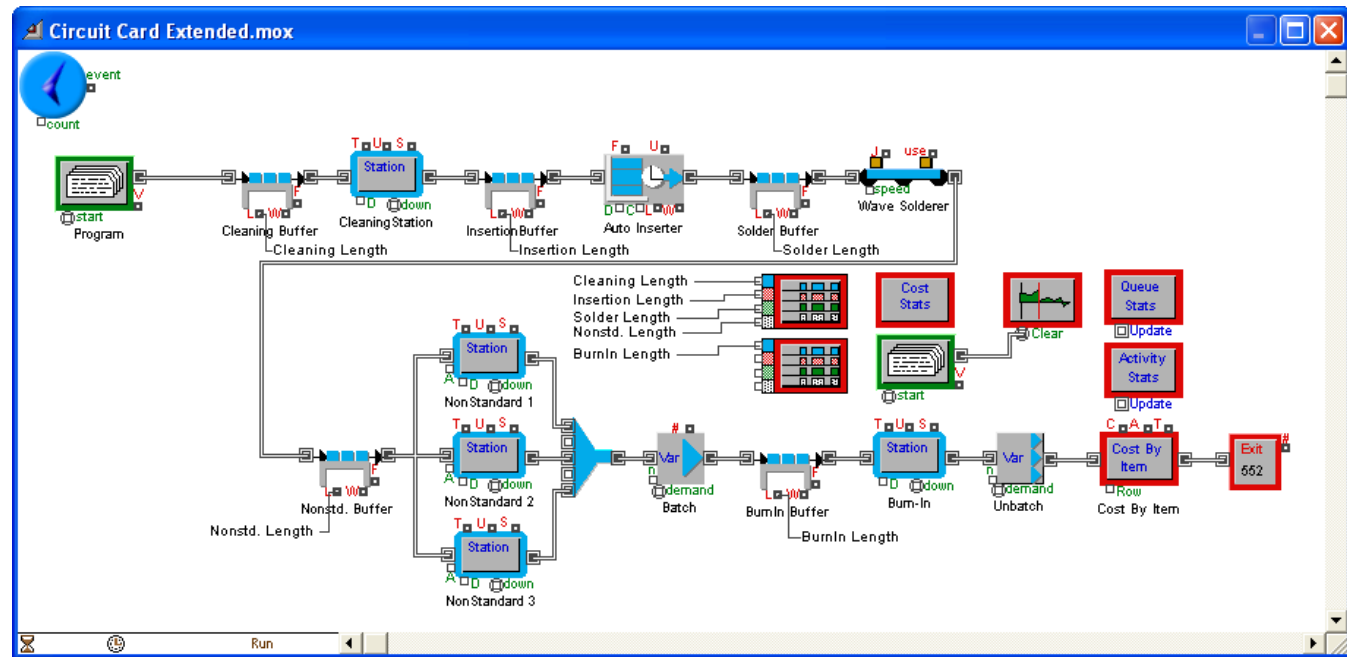

Source: Strickland, Discrete Event Simulation Using Extend, 2009



# Integrating Engineering-Level Simulations

- The process of integrating engineering-level simulations is similar to the process of integrating a system
  - Each simulation acts as a component of the integrated simulation (often referred to as a “federation” of simulations)
  - Data interchange agreements for simulations are like interface control documents for systems
- Engineering-level simulations can be integrated with one another
  - Through sequential passing of data from one simulation to the next
    - Possible if there are no significant “feedback” paths
    - Can be done through automation, or manually (a.k.a. “sneaker net”)
  - Through run-time interoperability (e.g., using the High Level Architecture for simulation interoperability, IEEE 1516)
    - Requires pre-execution agreements as to which simulations “publish” and “subscribe to” data elements
    - Requires a run-time infrastructure to manage execution



# Integrating Engineering-Level Simulations Through Sequential Data Passing

- Need to establish that a given simulation produces outputs that are compatible with inputs required by the next simulation in the sequence, either directly, or by some well-defined transformation
  - “Post-processing” and/or “pre-processing” steps may be required to ensure output-input compatibility
- “Syntactic” interoperability – refers to ensuring that the (post-processed) data outputs are the same data element and are in the same units of measure as the (pre-processed) data inputs
- “Semantic” (or “substantive”) interoperability – refers to ensuring that the (post-processed) data outputs and (pre-processed) data inputs have the same meaning in both simulations
  - For example, if a simulation generating “speed” data assumes over-the-ground speed and the data-receiving simulation assumes through-the-air speed, there is no semantic interoperability
- Both syntactic and semantic interoperability are needed for two simulations to be “composable”



# Integrating Engineering-Level Simulations Through Run-Time Interoperability

- Most engineering-level simulations require
  - Causality: The effects of an action are observed after the action occurs
  - Repeatability: The simulation gives the same result if executed twice
- Ensuring causality and repeatability requires a method for maintaining “event ordering” at run-time
  - This is a non-trivial problem when executing several simulations interactively across a network, in which packets may arrive in a different order from the order in which they were generated
- Other issues for simulations interacting at run-time
  - Maintaining a consistent environment (terrain, weather) over time
  - Deciding which simulation should have control of an entity at a given time
  - Managing the number of interactions required (e.g., having a maximum range for a sensor so not every sensor-target pair needs to be evaluated)
  - Detecting that another simulation has stopped executing





# Time Management in Simulations

## Interoperating at Run-Time – Time Definitions

---

- Wallclock time - The actual time of day during a simulation execution (e.g., today from 4 pm to 6 pm)
- Physical time - The time in the physical system being modeled being modeled by the simulation (e.g., from midnight to 6 pm on December 7, 1941)
- Simulation time (logical time) - The simulation's representation of physical time (e.g., double-precision floating point number between 0 and 18, where a simulation time unit represents an hour of physical time)
- Federate time - The logical (simulation) time within a particular simulation federate at any instant during a distributed simulation execution



# A Logical View of Time Management (from the High Level Architecture)

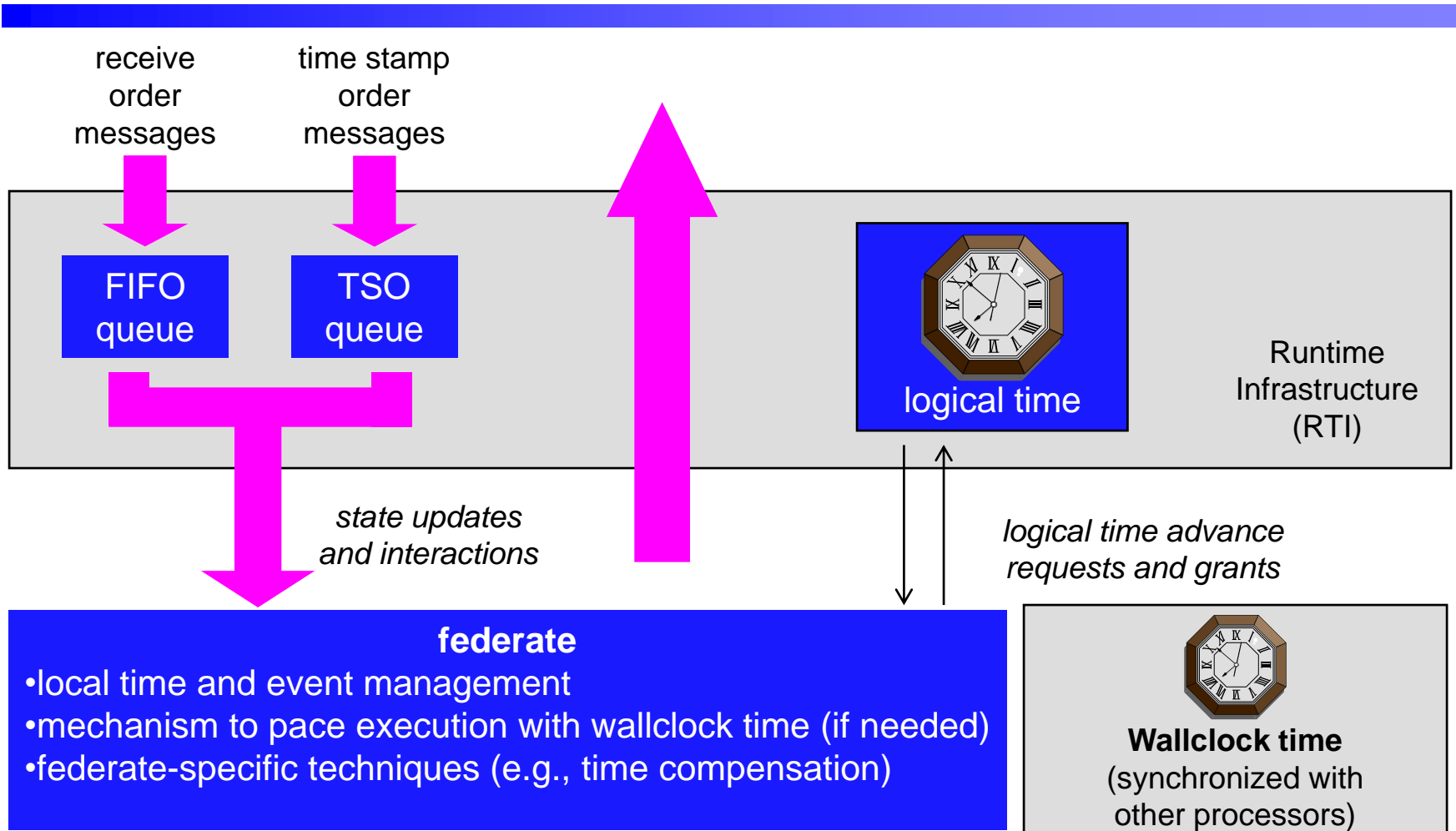

from Fujimoto 1998, "Time Management in the High Level Architecture," Figure 2



## Module Summary

---

- A broad range of engineering disciplines are involved in design and development, thus requiring a broad range of models and simulations, primarily at the engineering level.
- A systems engineer responsible for M&S needs to have a broad view of M&S tools that can be applied in a range of disciplines during this phase.
- The process of integrating engineering-level simulations is similar to the process of integrating a system
- Engineering-level simulations can be integrated with one another
  - Through sequential passing of data from one simulation to the next
  - Through run-time interoperability
- Both syntactic and semantic interoperability are needed for two simulations to be composable
- Most engineering-level simulations require causality and repeatability
- Event ordering and time management are important for engineering-level simulations with run-time interoperability requirements

# Modeling and Simulation in Integration and Test & Evaluation



# Module Objective and Outline

---

Module Objective: To describe the use of modeling and simulation in the integration and test & evaluation phase of the systems engineering process; and to describe special issues particular to this phase.

## Module Outline

- Scope of Integration and Test & Evaluation (T&E)
- A Simplified Process Model for Integration and T&E
- Simulation Use During Integration
- Planning for Use of Models and Simulations During T&E
- Simulation Use During Testing
- Post-Test Evaluation Using Models and Simulations
- Summary



# Scope of Integration and Test & Evaluation (T&E)

---

- The integration and T&E phase of systems engineering, as discussed in this course, corresponds to the Integration and Evaluation phase in the Kossiakoff and Sweet textbook
- Integration takes unit-tested components and subsystems and forms them into an integrated system
- Test and evaluation (T&E) of military systems is typically divided into
  - Developmental test and evaluation (DT&E) conducted under the auspices of the system's program manager
  - Operational test and evaluation (OT&E) conducted by an independent operational test agency (OTA)
- Integration and test activities are typically aided by live, virtual, and constructive simulations running at or near real time
- Evaluation activities sometimes involve models of the system and its components to aid in determining the source of unexpected test performance



# A Simplified Process Model for Integration and T&E

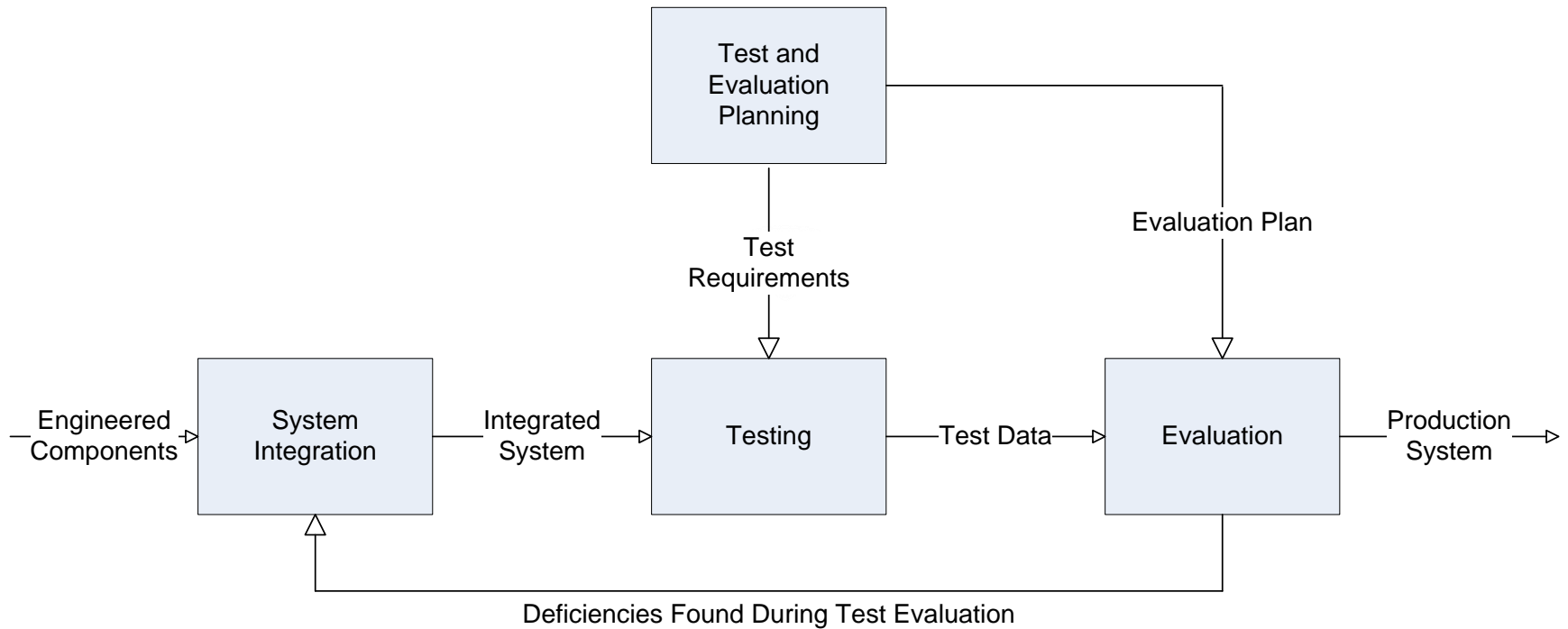



## Simulation in Integration – Use of Stimulators

---

- As one proceeds from unit testing to system integration, there is often a need for “stimulators” to represent a part of the system (or the external environment) that is not currently available for integration
- Examples of stimulators:
  - Generation of an infrared (IR) scene to be sensed by an IR seeker
  - Representation of a radar (or other sensor) output as it would be presented to its processing system
  - Representation of a potential human operator’s input to a vehicle control system
- Gradually substitute real system components for simulated system components until full system is integrated





# Simulation Issues of Particular Interest During Integration

---

- Representativeness of integration environment as compared to the intended operational environment
  - Are characteristics of the simulated external environment sufficiently realistic, in terms of frequency, intensity, etc.?
- Real-time operation (often “hard-real-time”)
  - Can the software simulation of a hardware component operate quickly enough?
  - Can simulation/stimulation components adequately represent the frequency and periodicity of the real system components?
- Similarity of simulator/stimulator interfaces to those of the objective system component
  - Are the interfaces of the simulator/stimulator the same as those of the system component being represented? Or sufficiently similar so that differences can be accommodated without sacrificing realism?



# Planning for Use of Models and Simulations During T&E

---

- Need to determine the appropriate integrated combination of **models, simulations, and test events** to obtain the most credible data with which to conduct a comprehensive evaluation of system performance
  - Are there situations where **safety** precludes testing?
  - Are there **physical constraints** (e.g., size of test range)?
  - Are there **fiscal constraints** (e.g., for system of systems testing)?
- Need to identify areas where actual **testing either can be augmented by M&S or used to validate** the models and simulations
- Need to summarize the **model, simulation, and data verification, validation, and accreditation (VV&A)** to be conducted
- Need to document how the **integrated use of accredited models and simulations with operational testing** will increase the knowledge and understanding of the capabilities and the limitations of the system as it will be employed
- Need to include the **resources required to perform VV&A** of the models and simulations; **to obtain and maintain** the models and simulations; and the resources required **to archive data**

# The Model-Test-Model (MTM) Paradigm

- The Model-Test-Model (MTM) paradigm refers to the iterative use of models & simulations and testing to refine the modeled representation of a system
- Start with a best estimate of the system's performance as represented in a model or simulation
- Conduct testing on the (prototype) system to collect data on how the system performs in reality
- Use the data collected to refine the modeled representation of the system's performance
- Repeat as necessary until the modeled representation of the system is deemed adequate

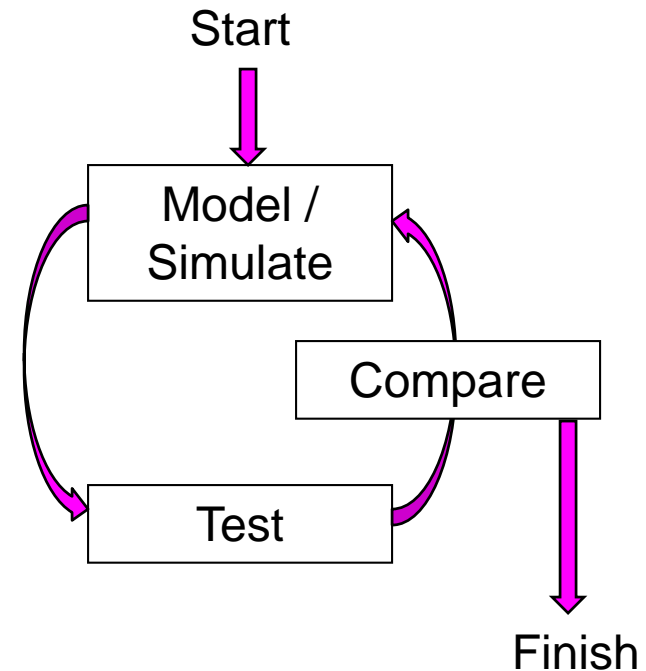

# The Simulation Test and Evaluation Process (STEP) – a 1990s DoD Attempt at Integrating M&S and T&E

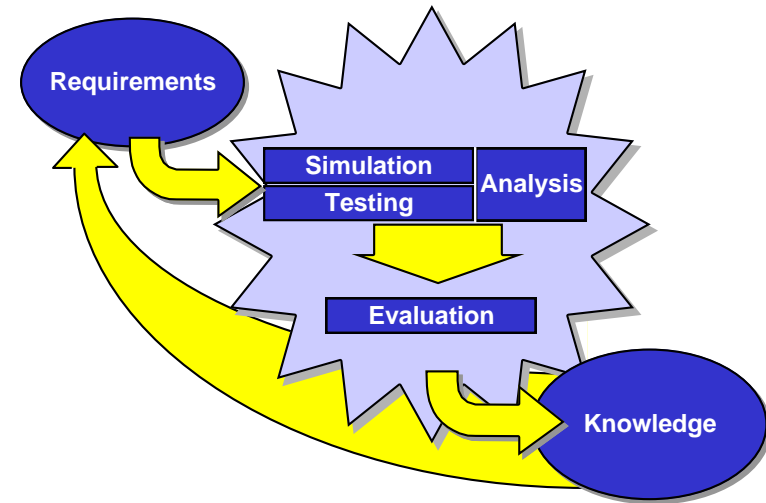
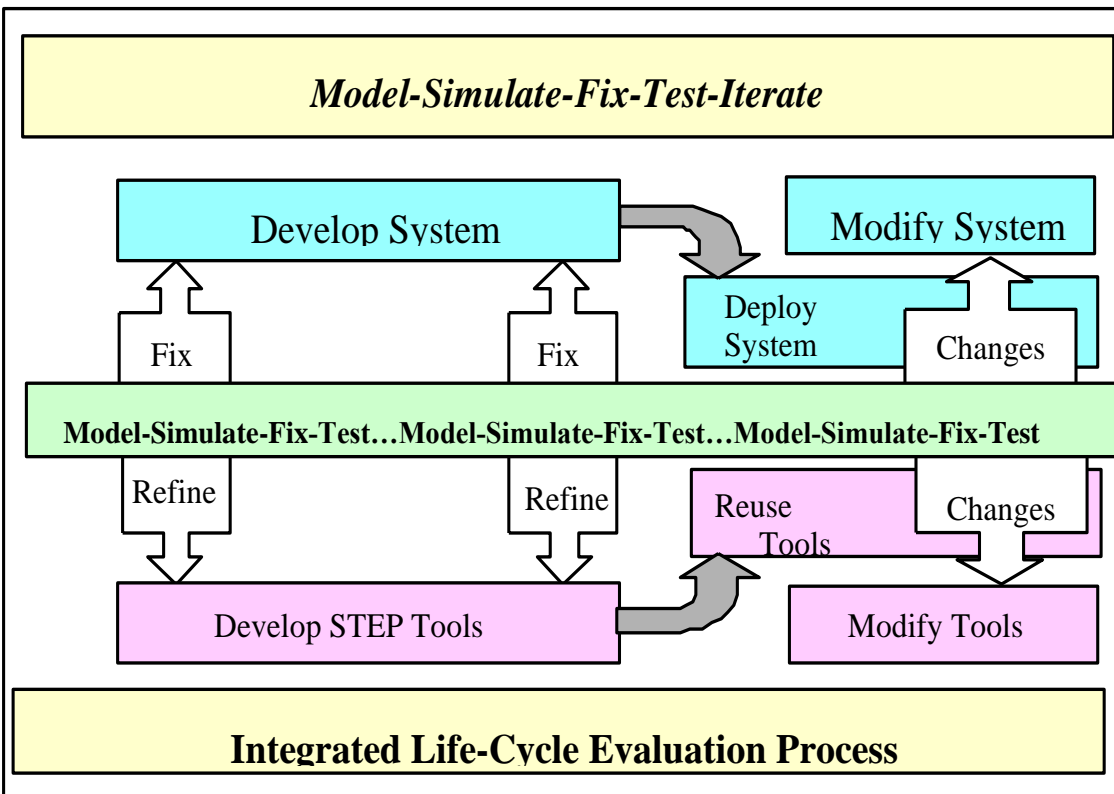

Source: Simulation, Test, and Evaluation Process (STEP) Guidelines, Director, Operational Test and Evaluation, and Director, Test, Systems Engineering and Evaluation, 4 Dec 1997.



# Hardware- and Software-in-the-Loop Simulations For Testing

---

- Hardware-in-the-loop (HWIL) simulations are a good example of simulations that are generally not (or need not be) computer-based
  - Examples:
    - Wind tunnels for missiles and aircraft
    - Anechoic chambers for radar seekers
    - Scene generators for focal plane arrays
    - Tow tanks for maritime vehicles
    - Pressure chambers for submersible vessels/housings
    - Crash-test facilities for automobiles
    - Shake tables for mechanical structures
    - Vacuum chambers for spacecraft
  - Require calibrated instrumentation to collect data on the system under test
- Software-in-the-loop (SWIL) simulations embed actual system software in a synthetic environment representing the system's intended use

# Examples of HWIL Facilities



NASA wind tunnel with aircraft model



Benfield Anechoic Facility at Edwards Air Force Base



NHTSA crash test

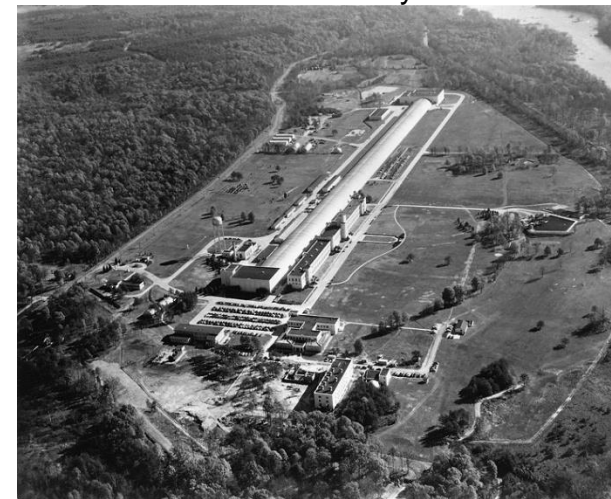

David Taylor Model Basin, Carderock



# SWIL Example – JHU/APL Cooperative Engagement Processor (CEP) Wrap-Around Simulation Program (WASP)

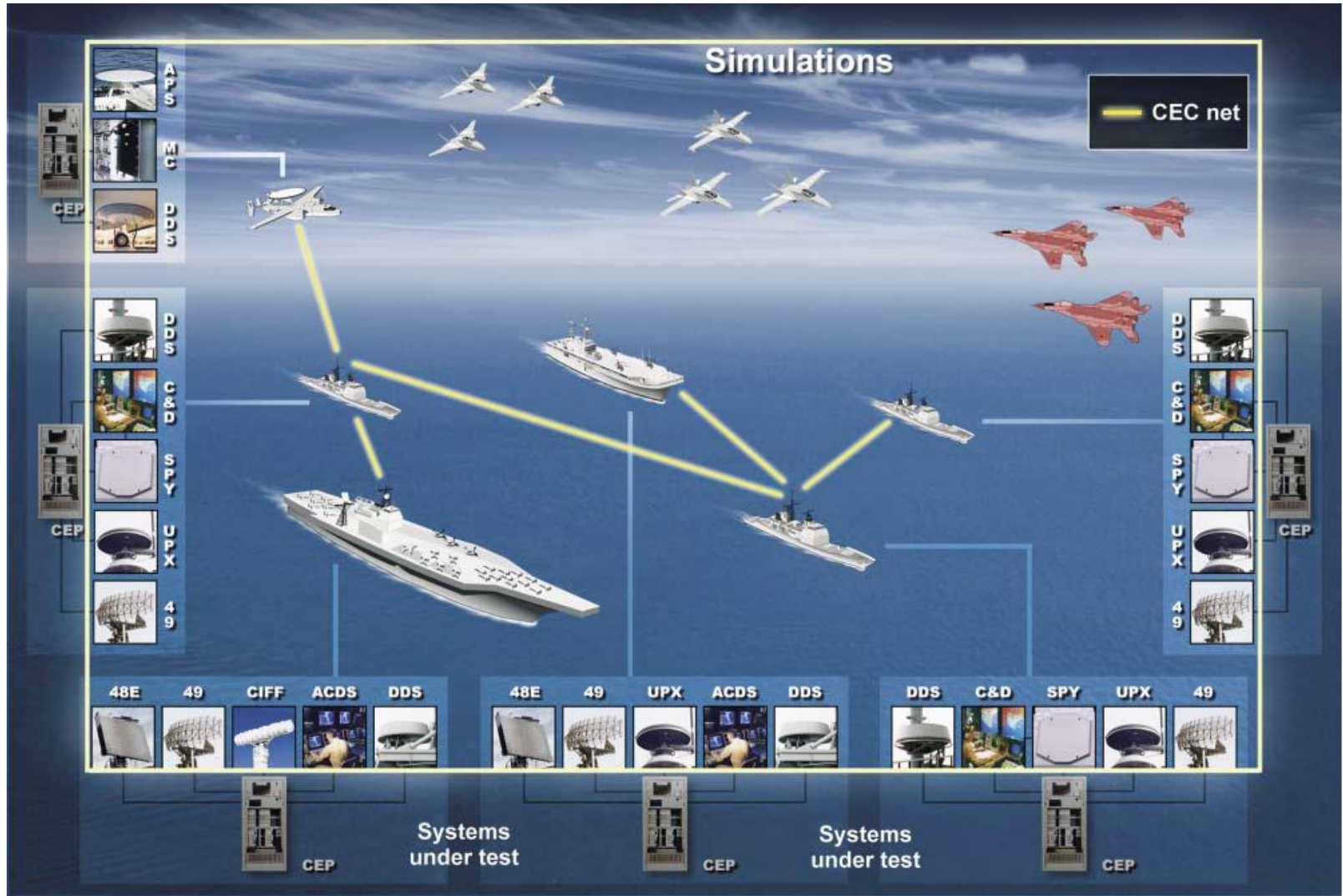



# Pre-Test Predictions Using Models and Simulations

- In modern-day system acquisition, having a (perceived) failure during a highly visible system test can de-rail the system development process
- By modeling the system's performance in the test environment prior to the actual test, one can
  - Vary environmental parameters to determine if there are any situations in which the test should be delayed because of excessive risk (e.g., extreme wind shear conditions, extreme hot or cold temperatures)
  - Establish an “objective” benchmark with which to compare the actual test results
    - Aids in determination as to whether the test was “successful”
  - Determine boundaries of realistically expected performance, for evaluating/ensuring safety during the test
    - For example, “three-sigma” ballistic missile trajectory envelopes for range-safety decisions on whether to destroy the missile





## Simulation Use in Test Range Activities

---

- Simulate assets (targets, friendly systems/platforms) not available in the range environment using constructive simulations
  - For large scale “system-of-systems” tests requiring demonstration of inter-system interoperability
- Supplement natural environment on the test range with simulated natural environment features not present on the test range
- “Geo-relocate” live test assets from other test ranges

# TENA Middleware Architecture

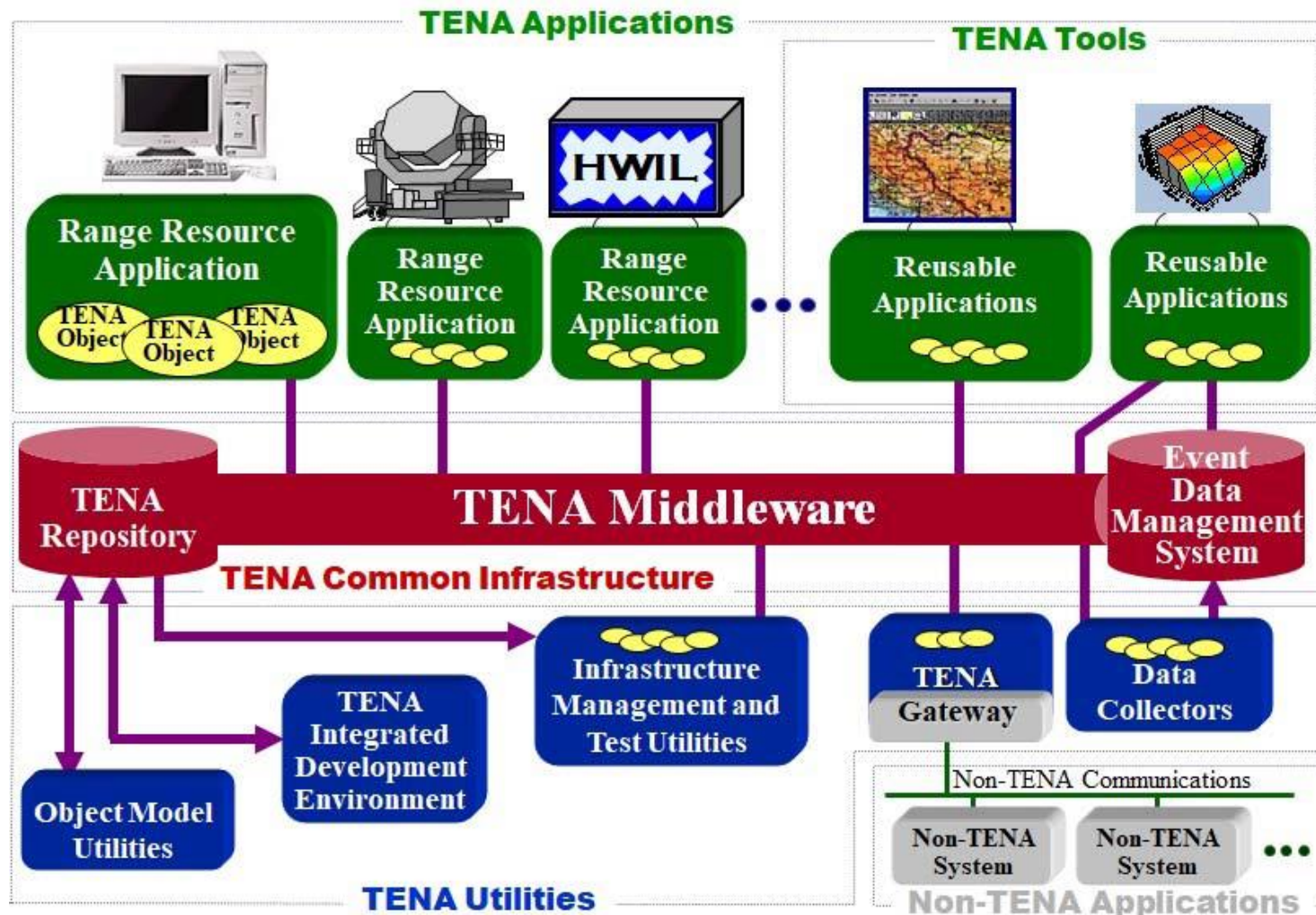

Source: "TENA Overview Fact Sheet," <https://www.tena-sda.org/attachments/TENA-Overview-2018-06-11-DistA.pdf>

# Joint Mission Environment Test Capability (JMETC) Distributed Test Architecture



Source: "JMETC Overview Fact Sheet", <https://www.tena-sda.org/attachments/JMETC-Overview-2017-10-03-DistA.pdf>



# Simulation Issues of Particular Interest During Testing

---

- Latency of transmissions across the network of constructive, virtual, and live assets
  - Need to maintain representative “real-time” interactions
- Bandwidth of networks
  - For example, environmental data often needs to be “pre-loaded” because of bandwidth constraints
- Time synchronization among geographically distributed systems
  - GPS time source often used
- Consistency of environmental representations across live, virtual, and constructive simulation assets
- Potential safety issues introduced by adding constructive or virtual targets to a live display
  - For example, introducing simulated threat aircraft in a heads-up cockpit display could result in evasive maneuvers into a real mountain



# Post-Test Evaluation Using Models and Simulations (1 of 2)

---

- Single-test results
  - Comparison of test results to pre-test model/simulation predictions
  - If results differ from predictions:
    - Are test results within a statistically-expected range?
    - Are there differences in the day-of-test environment from the predicted environment?
      - If so, can do a “post-test prediction” based on the day-of-test environment
    - Does test data indicate an obvious anomaly in performance?
  - If differences appear to be “real”:
    - Is there an algorithmic error in the model/simulation?
    - Is there an un-modeled effect that could account for the difference?
    - Is it appropriate to “calibrate” the model/simulation based on a single test?





# Post-Test Evaluation Using Models and Simulations (2 of 2)

---

- Multiple-test results
  - Comparison of multiple test results to pre-test (or post-test) model/simulation predictions
  - Unfortunately, except for “high-value systems” (e.g., Navy Trident missile system), it is seldom possible to conduct enough full-system tests to get statistically significant results
  - Is there a pattern (bias) of the test results when compared to the model/simulation predictions? If so,
    - Is there an algorithmic error in the model/simulation?
      - Can use of statistical modeling techniques (e.g., Kalman filter) help to reveal the source of the error?
    - Is there an unmodeled effect that could account for the difference?
    - Is it appropriate to “calibrate” the model/simulation based on this number of tests?

# Example of Multi-Test Evaluation

## JHU/APL Trident II Accuracy Evaluation

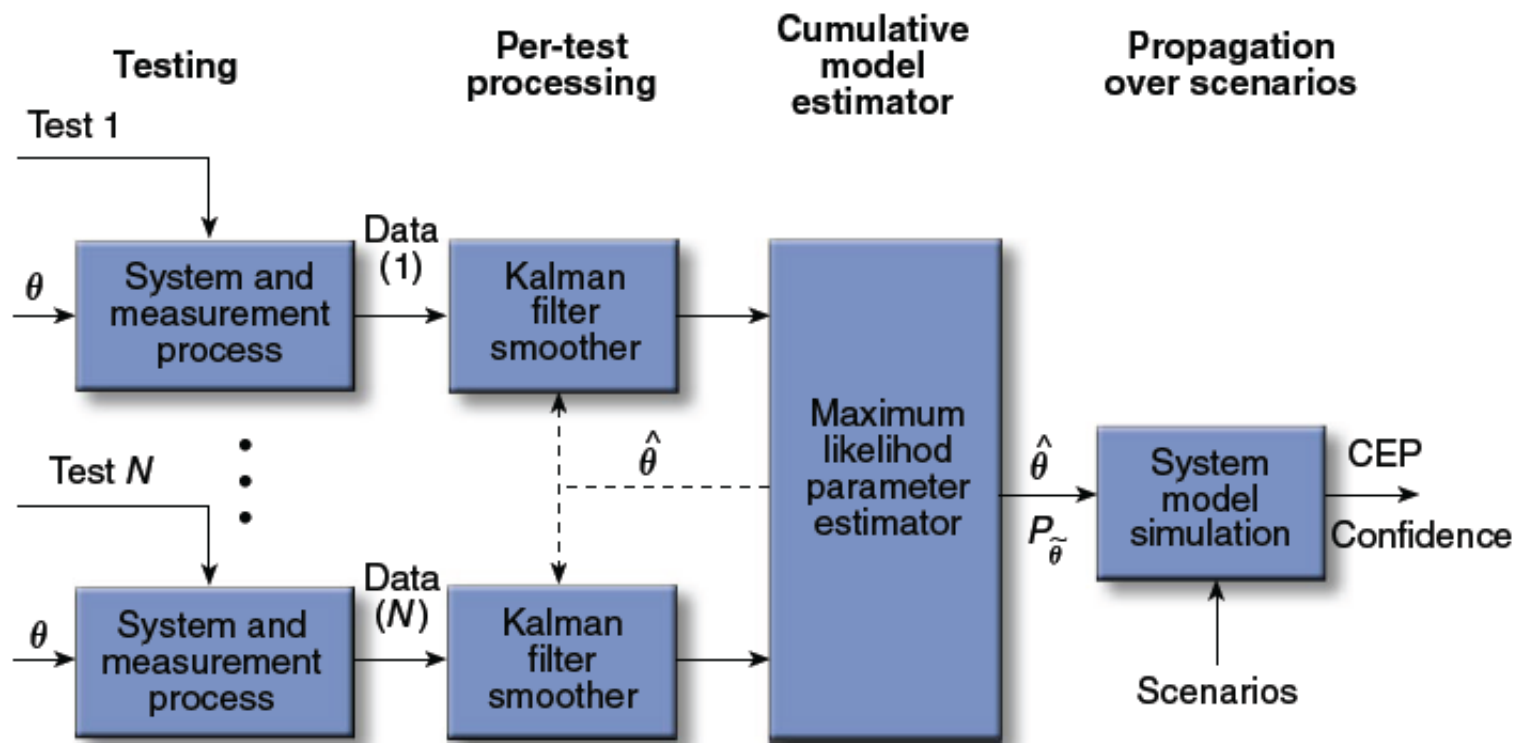

**Figure 5.** Model estimation for Trident II resulting in the credible performance prediction of a critical system to the government and military system. ( $\theta$  = true model parameter vector,  $\hat{\theta}$  = estimate of  $\theta$ ,  $P_{\hat{\theta}}$  = covariance of estimation error in  $\theta$ .)

Source: Levy, L.J., "The Systems Analysis, Test, and Evaluation of Strategic Systems," APL Tech. Digest, Vol. 26, No. 4 (2005), pp. 438-442.



## Module Summary

---

- In system testing, there is often a need for “stimulators” to represent a part of the system (or the external environment) that is not currently available for testing
- Use of models and simulations during T&E must be planned well in advance, in conjunction with the overall T&E plan
- Models and simulations are instrumental in pre-test predictions of system performance
- Simulations are essential to represent assets (threat and friendly) not available for system testing
- Models of the system under test and its components are useful in determining the specific source of differences between pre-test predictions and system test performance



# Modeling and Simulation in Production and Sustainment



# Module Objective and Outline

---

Module Objective: To describe the use of modeling and simulation in the production and sustainment phase of the systems engineering process; and to describe special issues particular to this phase.

## Module Outline

- Scope of Production and Sustainment
- A Simplified Process Model for Production and Sustainment
- Planning for Use of Models and Simulations During Production
- Model and Simulation Use During Production
- Model and Simulation Use During Sustainment
  - Systems Operation Simulations
  - Reliability Modeling
  - Logistics Simulations
  - Ownership Cost Modeling
- Summary



# Scope of Production and Sustainment

- The Production and Sustainment phase of systems engineering, as discussed in this course, corresponds to the Post-Development Stage, consisting of the Production and Operations & Support phases, in *Systems Engineering: Principles and Practice* [1].
- Production takes the production design that results after Test & Evaluation, and “realizes” one or more instances of the system
  - Relatively straightforward for software-only systems
  - Can be quite complex for hardware systems
- Sustainment, which includes Operations and Support, is typically the lengthiest phase for a system, lasting as long as 60 years for large-scale military systems (e.g., aircraft carriers and the B-52 bomber)
  - Can incur up to 50% of the Total Ownership Cost (TOC) of a system
  - Planning for Sustainment (and Disposal) using models and simulations needs to occur early in the systems engineering process

Source: (1) Kossiakoff, A., Sweet, W. N., Seymour, S. J., and Biemer, S. N., *Systems Engineering: Principles and Practice, Second Edition*, John Wiley & Sons, Inc., Hoboken, N. J. (2011).



# Military System Total Ownership Cost by Phase, and When Determined

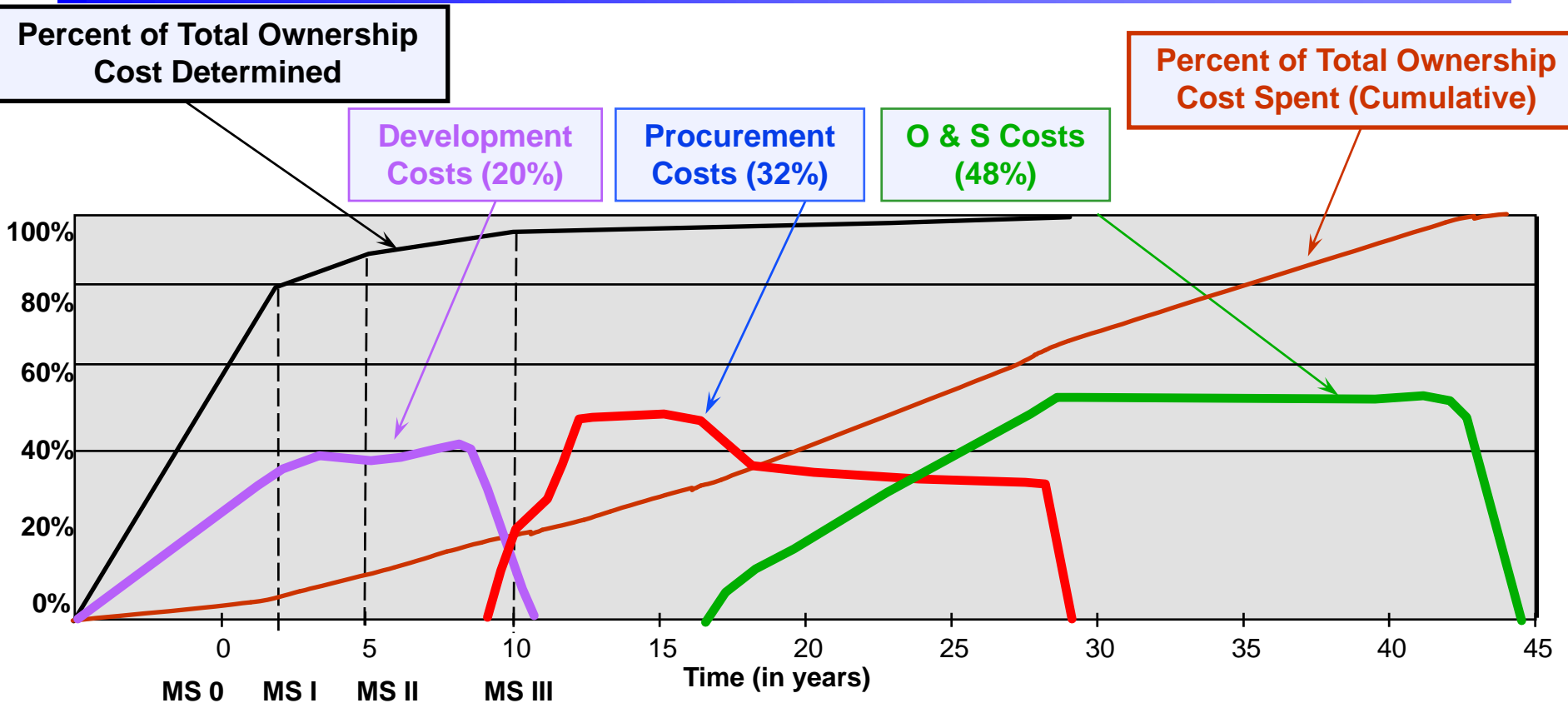

**Efficient Exploration of the Design Space Early in the Program Is Key to Reducing Total Ownership Cost**

Source: *The Simulation Based Acquisition Vision: A Brief Tutorial*, Nicholas E. Karangelen, March 1998



# A Simplified Process Model for Production and Sustainment

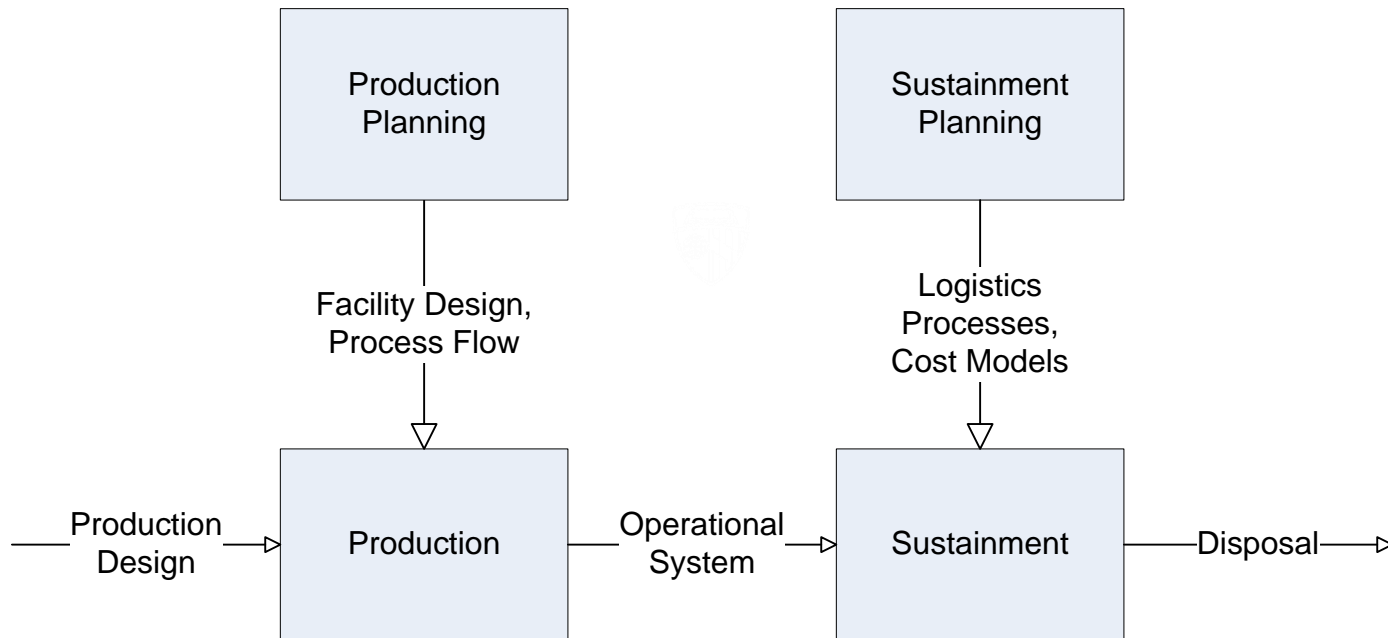



# Planning for Production Using Models and Simulations

---

- Just as one needs to plan early for Test and Evaluation, one also needs to plan early for Production, particularly for hardware systems
  - What rate of production is required?
  - How large does a facility (do facilities) need to be?
  - What is a good production process?
- Ensuring that computer-aided design (CAD) models of the system produced during Design and Development can flow seamlessly into computer-aided manufacturing (CAM) equipment
- Modeling the design of production facilities (using CAD)
- Simulating the flow of the system assembly process (using process models, such as Arena)



## Model and Simulation Use During Production

---

- CAD models of the system produced during Design and Development are ingested by CAM equipment to automate component manufacturing
- Models of production manufacturing facilities created during Design and Development are refined, based on the production design of the system
- Simulations of the flow of the manufacturing process are executed, and the process iterated
  - To optimize the assembly line itself
  - To optimize the timing of the flow of component parts into the system assembly facility



# Examples of Production Facilities



USAF TB-32 production line



P-51D assembly line



F-35 (Joint Strike Fighter) production facility

Source for photos: Wikimedia Commons. All of these photos are in the public domain.



# M&S Standards in Production – Standard for the Exchange of Product Model Data (STEP)

## AP 203: Configuration Controlled 3D Designs of Mechanical Parts and Assemblies



### Configuration Management

- Authorisation
- Control (Version/Revision)
- Effectivity
- Release Status
- Security Classification
- Supplier

### Geometric Shapes

- Advanced BREP Solids
- Faceted BREP Solids
- Manifold Surfaces with Topology
- Wireframe with Topology
- Surfaces and Wireframe without Topology

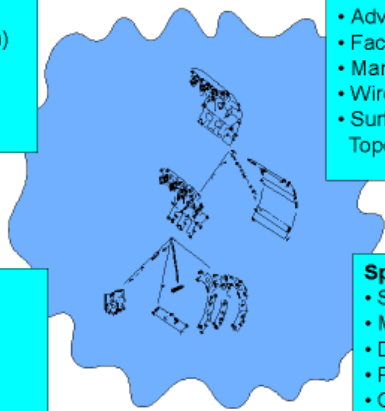

### Product Structure

- Assemblies
- Bill of Materials
- Part
- Substitute Part
- Alternate Part

### Specifications

- Surface Finish
- Material
- Design
- Process
- CAD Filename

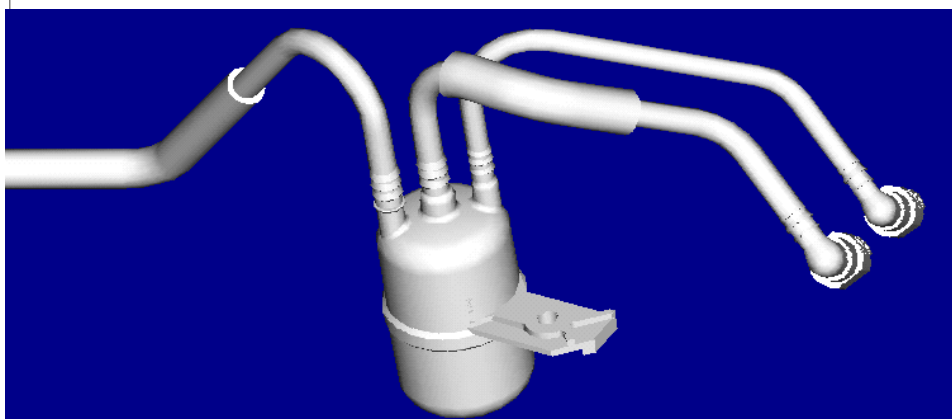

- Boeing Commercial Aircraft
- Boeing CSTAR
- Delphi Automotive Systems
- Lockheed Martin
- NASA

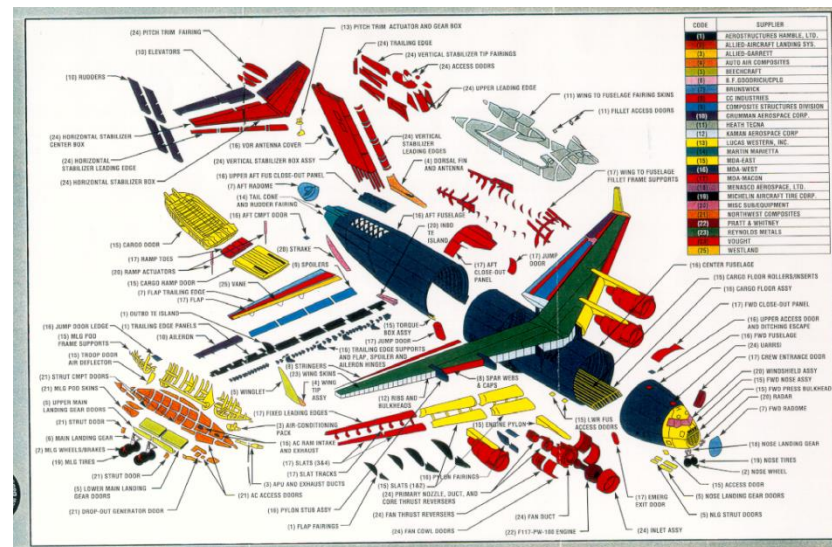

Source: *Manufacturing Interoperability & the Manufacturing Systems Integration Division*, Steven Ray, Ph.D., National Institute of Standards and Technology, May 11, 2001



# M&S Standards in Production – Core Manufacturing Simulation Data (CMSD) Standard

---

- Approved as a Simulation Interoperability Standards Organization (SISO) standard, spring 2010
- Utilizes Unified Modeling Language (UML) class and package diagrams
- CMSD information categories:
  - Calendar information
  - Resource information
  - Skill information
  - Setup information
  - Part information
  - Bill-of-materials information
  - Inventory information
  - Process plan information
  - Maintenance plan information
  - Order and Job information
  - Schedule information
  - Reference information
  - Probability distribution information



## Model and Simulation Use During Sustainment

---

- Operations of the system are simulated under controlled conditions to reproduce system failures experienced in the operational environment, and to investigate potential solutions
- Reliability, Availability, and Maintainability of the system are modeled and re-modeled periodically, using data from systems in the operational environment
- Logistics for the repair and supply/re-supply of spare parts for the system are simulated
- Ownership costs are modeled on a continuing basis



# Systems Operation Simulations

---

- Simulators replicating, as closely as possible, the system or major subsystems thereof, are often operated and maintained for high-value and high-volume systems
- Examples
  - Simulators for systems operating in a remote environment (e.g., system work-arounds for Apollo 13, unmanned interplanetary spacecraft)
  - Subsystem simulators to investigate infrequent operational problems (e.g., reported anomalous auto acceleration events)
  - Simulations of system component failures for accident forensics (e.g., space shuttle wing penetration by foam during launch)



# Reliability, Availability, and Maintainability (RAM)

- Reliability – the probability that a system will perform its function correctly for a specified period of time under specified conditions
  - Typical metric: Mean Time Between Failure (MTBF)
- Maintainability – a measure of the ease of accomplishing the functions required to maintain a system in a fully operable condition
  - Typical metric: Mean Time To Repair (MTTR)
- Availability – the probability that a system will perform its function correctly when called upon
  - Typical metric: Probability of availability ( $P_A$ )
  - $P_A \approx 1 - \text{MTTR} / \text{MTBF}$  (for short repair times and low failure rates)
  - Note: Operational availability ( $A_o$ ) is often used as a data element in military campaign simulations

# Reliability Modeling

- The reliability of a system can be modeled as a mathematical function of the reliability of its components
  - For a system of 10 critical independent non-redundant components,
$$P_R = P_{r1} \times P_{r2} \times \dots \times P_{r10}$$
  - For a system with two independent redundant components with failure probabilities  $P_{f1}$  and  $P_{f2}$ ,
$$P_R = 1 - P_{f1} \times P_{f2}$$
- For a major system with many subsystems and components, the reliability model can become quite complicated, and is very dependent on accurate estimates of component reliabilities
- Example: Idaho National Laboratory (INL) SAPHIRE (*Systems Analysis Programs for Hands-on Integrated Reliability Evaluations*)
  - Implements Probabilistic Risk Assessment (PRA)
  - Used by NRC and NASA

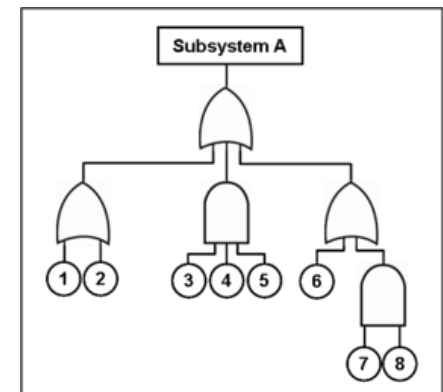

Fault tree diagram



# Repair and Spare Parts Logistics Simulations

---

- Similar to supply chain simulation during production of a system
- Essentially a process simulation tailored to the repair and supply/re-supply of spare parts for system support
- Various process modeling tools can be used
  - Arena
  - ExtendSim
  - AnyLogic
- Example logistics-specific models and simulations
  - Supply-Chain Operations Reference (SCOR) model
  - U.S. Air Force Logistics Simulation (LOGSIM)



# Ownership Cost Modeling

---

- Need to include all costs associated with continued ownership of a system
  - Personnel (operations and maintenance)
  - Fuel / power
  - Repairs and spare parts
  - ...
- A variety of ownership cost models exist
  - ACEIT (Automated Cost Estimating Integrated Tools)
  - SEER-H (hardware), SEER-SEM (software) [Galorath]
  - Automotive System Cost Modeling (ASCM) Tool [Oak Ridge]
  - Cost Analysis Strategy Assessment (CASA) [US Army LEC]
  - ...





## Module Summary

---

- Production of a hardware system must be planned well in advance, using models and simulations of facilities and processes
- Sustainment (operations and support) costs are usually the largest element of the ownership cost for major military systems
- Progress is being made in the development of standards for models and simulations used for production
- System operation simulations are useful for troubleshooting problems with systems operating in a remote environment
- Process modeling tools are important for both production and sustainment
- Reliability models can be quite complex for major systems
- System cost models need to consider the cost of all elements associated with the ownership of a system



# Typical Simulation Resolution Levels During Phases of the Systems Engineering Process

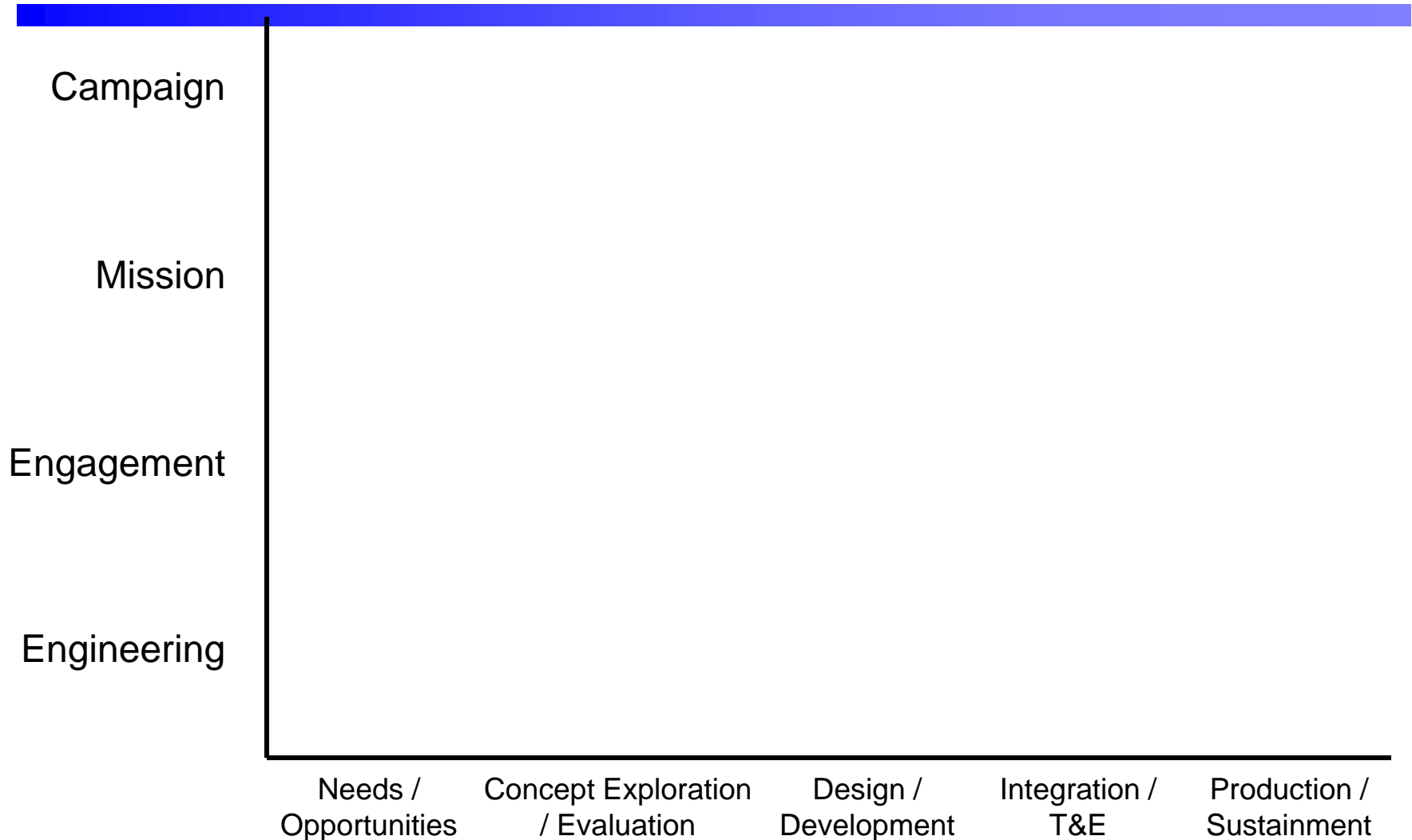



# Typical Simulation Resolution Levels During Phases of the Systems Engineering Process

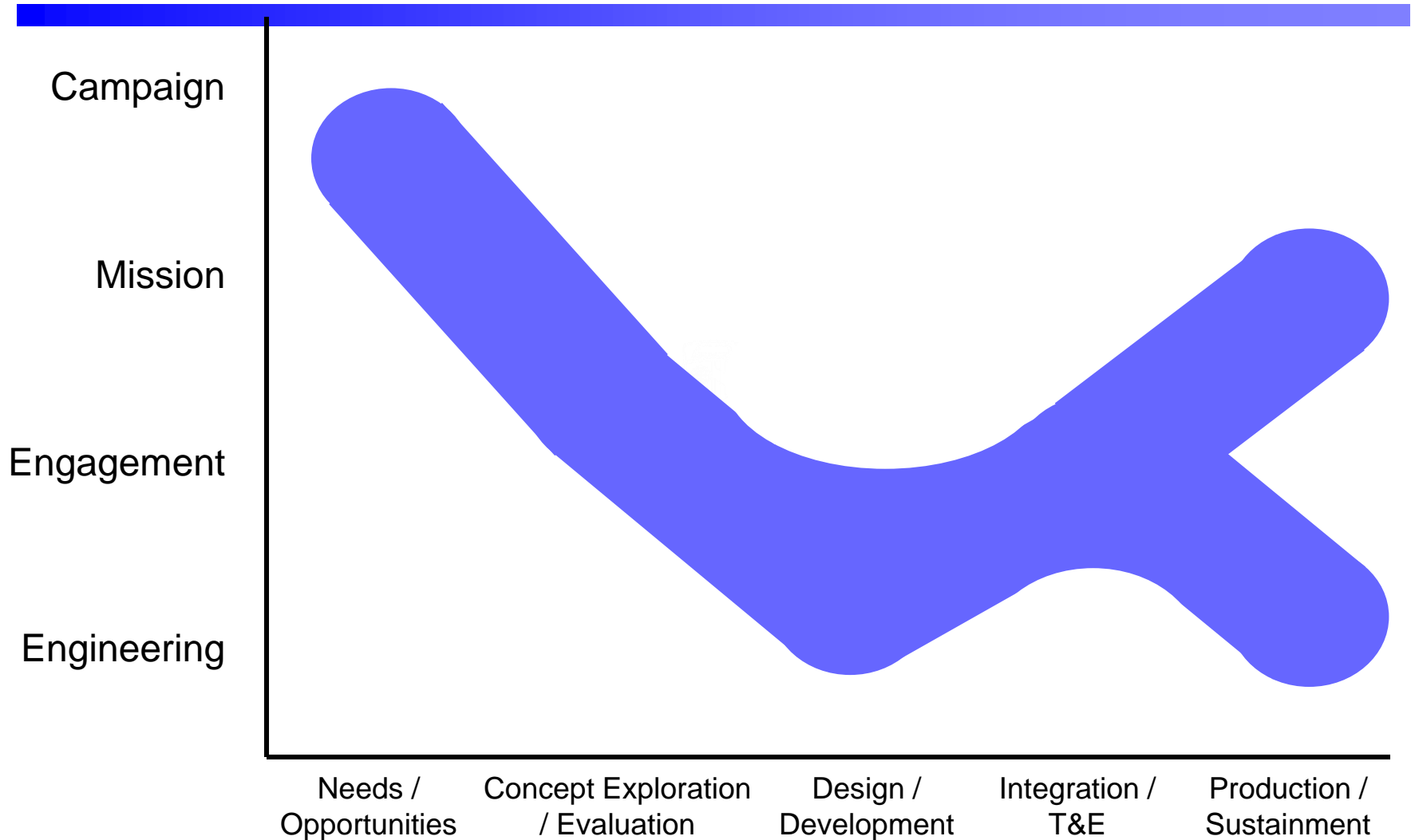



## Selected Detailed Examples (as time permits)

---

- System Effectiveness Simulation Examples
  - Conceptual model for a communications system
  - Logical data model for a scenario
- Interacting Simulation Examples
  - A Crisis Management and Evacuation System
  - A Mobile Missile System
- Integration and T&E Examples
  - Construction of a Simulation Environment for an Underwater Vehicle's Navigation and Sensor Data Systems
  - Construction of the M&S Portions of a Test and Evaluation Master Plan (TEMP)
- Repair Process for a Deployed Military System Component



# System Effectiveness Simulation Example – Conceptual model for a communications system (1 of 4)

- Question to be answered – how effective would a new radio frequency communications system be in a varied-terrain environment, in the possible presence of rain, with the possibility of jamming by an adversary?
- Develop a simulation conceptual model in graphical form
- What modeling and simulation components/elements are required?
  - Digital Terrain Elevation Data (DTED) for area of interest
  - Initial location and movement scripts for source, receiver, and jammer
  - Rain movement as a function of time
  - Probability of successful communication vs. distance in a benign line-of-sight environment
  - Degradation of probability of successful communication as a function of:
    - Distance of propagation through rain
    - Distance and azimuth of jammer relative to source and receiver
  - Other?



## System Effectiveness Simulation Example – Conceptual model for a communications system (2 of 4)

---

- Measure of effectiveness
  - Probability of successful receipt of a message in a (set of) representative operational environment(s)
- The system representation (in performance terms)
  - Source characteristics (frequency range, power levels, directionality)
  - Receiver characteristics (frequency range, sensitivity, directionality)
- The system's concept of operations
  - Rules on variations in power level selections and antenna pointing angle by operator
- The representation of threats and friendly systems
  - Jammer source characteristics (frequency range, power levels, directionality)
- The representation of the natural and man-made environment
  - DTED data (level 2)
  - Rain effects (attenuation by frequency range and rain density)

# System Effectiveness Simulation Example – Conceptual model for a communications system (3 of 4)

- The scenario
  - Movement scripts for source, receiver, and jammer
  - Rain density, expanse, and movement vs. time

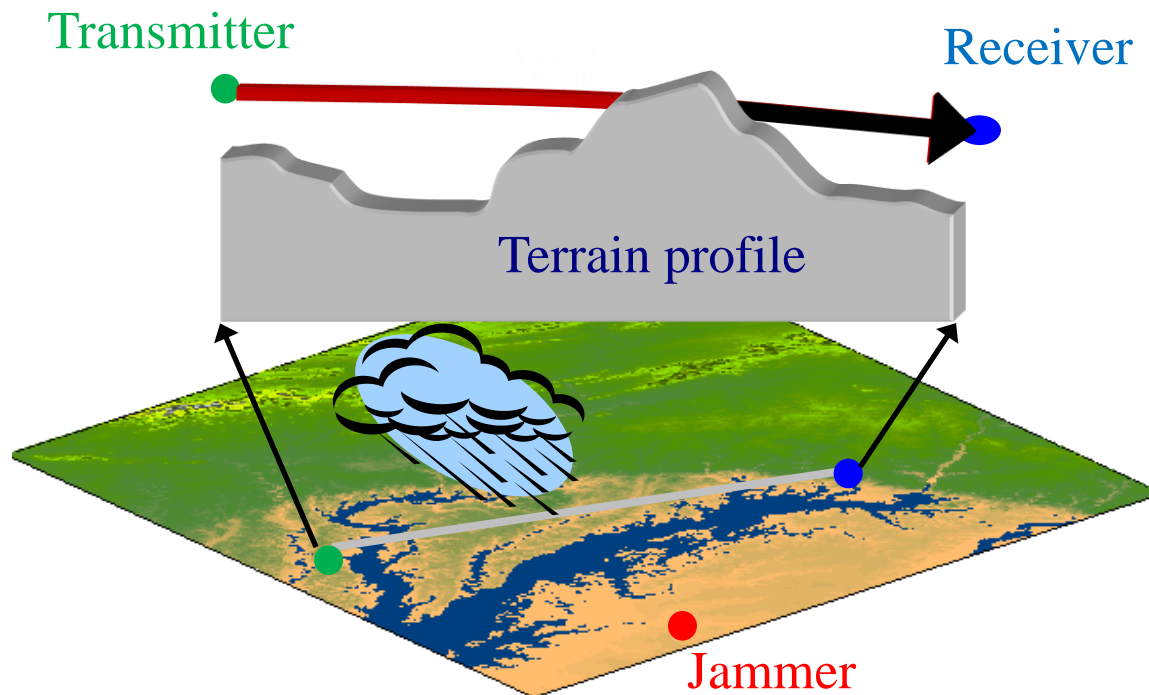



# System Effectiveness Simulation Example – Conceptual model for a communications system (4 of 4)

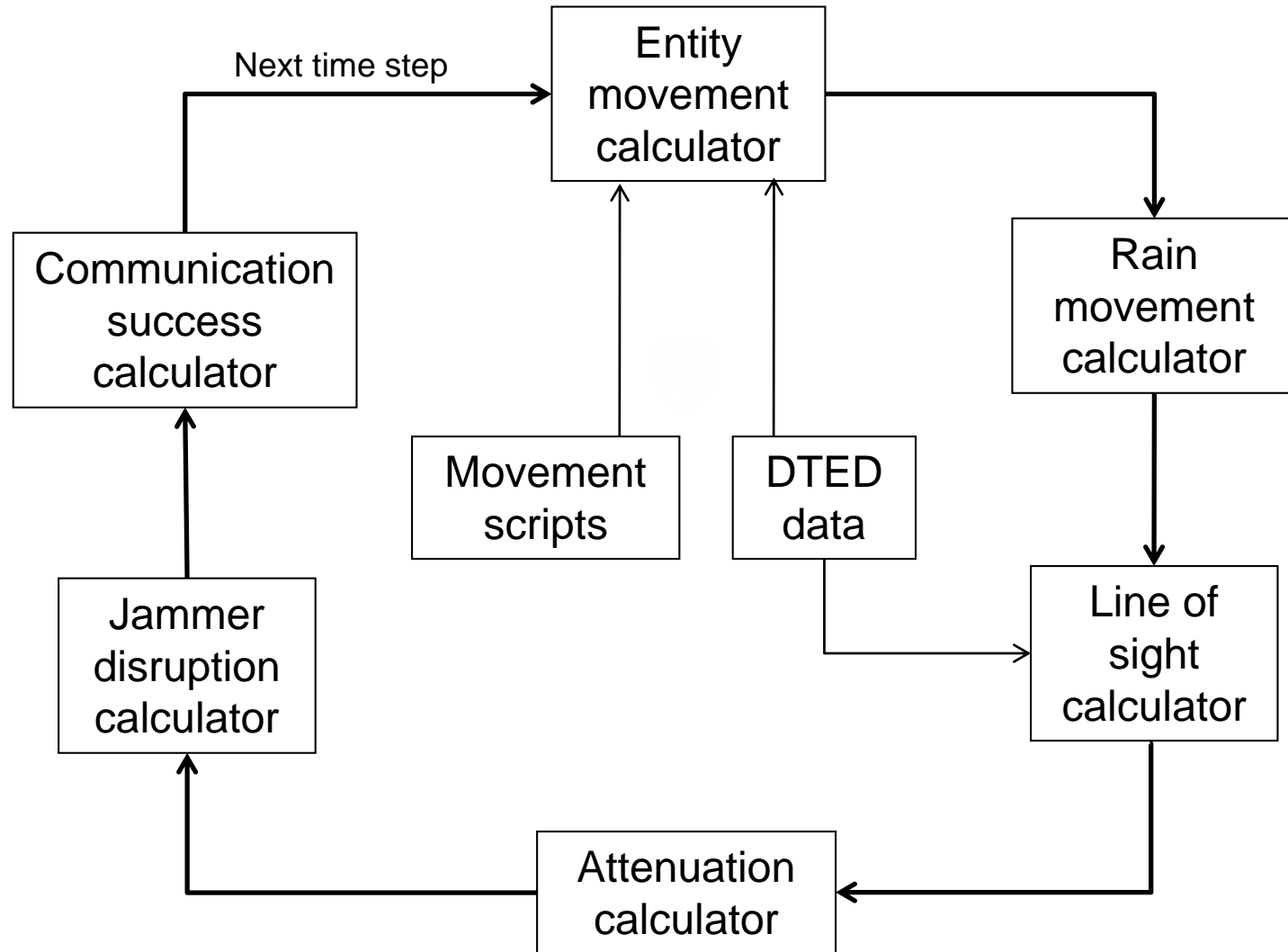





## System Effectiveness Simulation Example – Logical data model for a scenario

---

- A time of year and duration
- Location and extent of the play box(es)
  - Example: coordinate sets
- Instantiations of the natural and/or man-made environment
  - Example: environment sets
- The numbers and types of assets (system-of-interest, friendly, threat, neutral)
- System concepts of operation, and the way in which assets move
  - Example: scripted way points



# System Effectiveness Simulation Example – Logical data model for a scenario – Scenario identification

---

- Scenario ID
- Title
- Objective
- Author
- Date
- Start time (GMT)
- End time (GMT)
- Time step



# System Effectiveness Simulation Example – Logical data model for a scenario – Coordinate sets

- Coordinate sets may be expressed as multiple X-Y-Z or Lat-Lon-Alt points, in some reference frame, to define an area of interest (e.g., DTED region, play box, etc.)
- Coordinate set ID
- Coordinate set type (X-Y-Z or Lat-Lon-Alt)
- Reference frame (e.g., WGS 1984, UTM)
- Number of coordinate points
- For coordinate sets of type X-Y-Z:
  - Units
  - For each coordinate point:
    - X
    - Y
    - Z
- For coordinate sets of type Lat-Lon-Alt:
  - Lat-Lon units
  - Alt units
  - For each coordinate point:
    - Lat
    - Lon
    - Alt



## System Effectiveness Simulation Example – Logical data model for a scenario – Environment sets

---

- Environment sets can be used to describe the environment (land, air, sea) in an area of interest
- Environment ID
- Coordinate set ID reference
- For air environments:
  - Air parameters (e.g., cloud cover density)
- For sea environments:
  - Sea parameters (e.g., sea state)
- For land environments:
  - Land parameters (e.g., terrain height)



# System Effectiveness Simulation Example – Logical data model for a scenario – Assets

- Assets may be of a number of different types, and may be in alliances with other assets, with the alliances related as friendly, hostile, or neutral
- For each asset:
  - Asset ID
  - Asset classification (e.g., vehicle, command post, sensor)
  - Asset category, within classification (e.g., ship, radar)
  - Alliance ID reference
- For each alliance:
  - Alliance ID
  - Alliance name
  - Alliance asset IDs
- Alliance relationships – for each relationship:
  - Alliance type (friendly, hostile, or neutral)
  - “Subject” alliance ID
  - “Predicate” alliance ID



# System Effectiveness Simulation Example – Logical data model for a scenario – Asset movement

---

- Asset movement in a scenario may be scripted, by specifying a series of way-points and times, or by specifying a series of courses, speeds, and durations
- Way-point movement plan – for each movement:
  - Current coordinate set ID reference
  - Next coordinate set ID reference
  - Arrival time at next coordinate set (assume constant course and speed)
- Course-speed-duration movement plan – for each movement:
  - Course for movement (assume constant)
  - Speed for movement (assume constant)
  - Duration of movement



# Example of Scenario, Play Boxes, Environment Sets, and Coordinate Sets Relationships

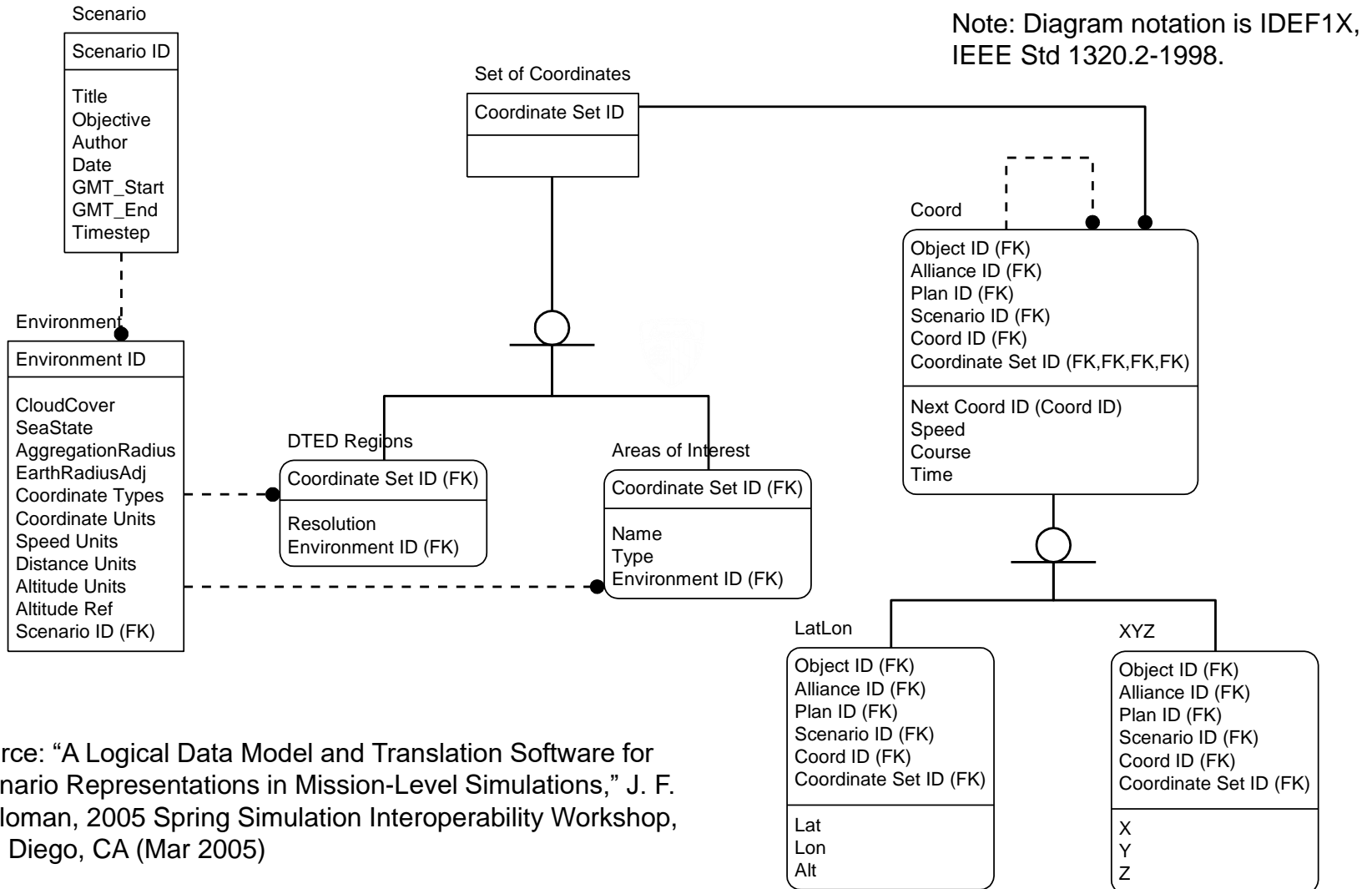

Source: "A Logical Data Model and Translation Software for Scenario Representations in Mission-Level Simulations," J. F. Schloman, 2005 Spring Simulation Interoperability Workshop, San Diego, CA (Mar 2005)



# Example of Asset Relationships

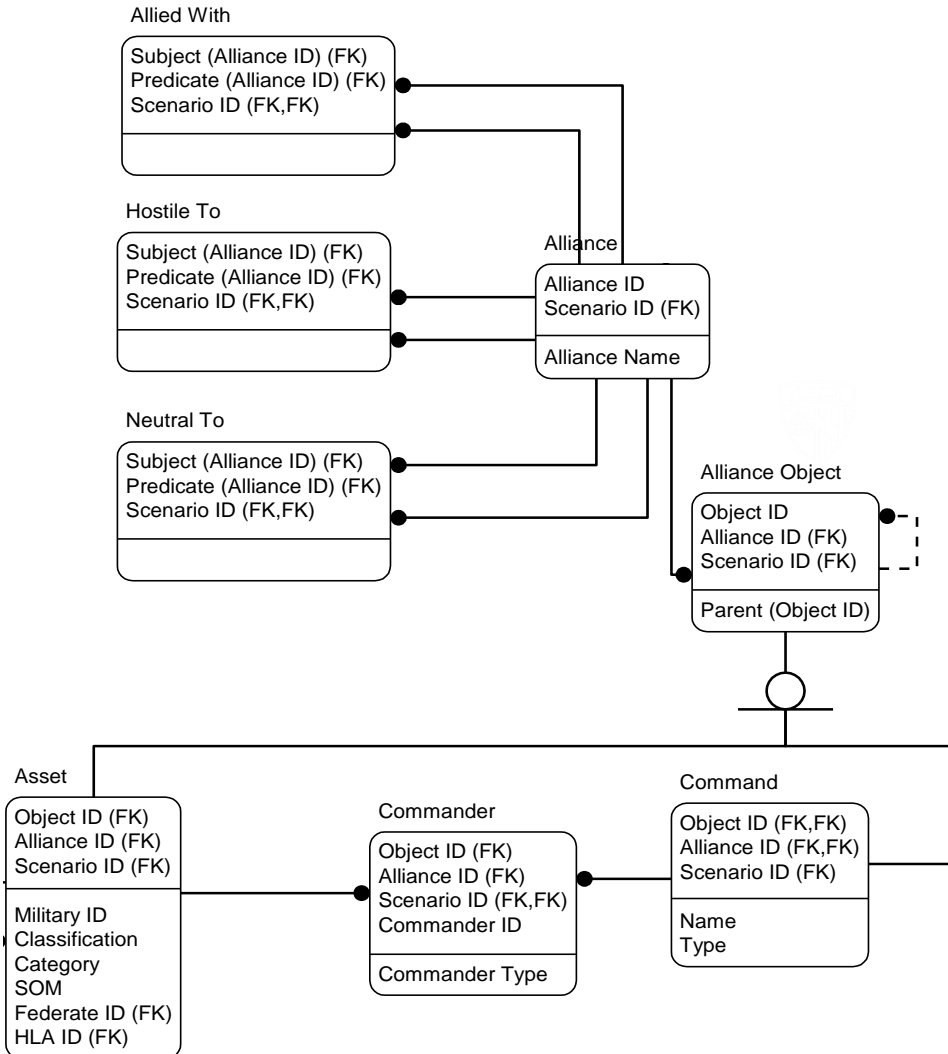

Note: Diagram notation is IDEF1X, IEEE Std 1320.2-1998.

Source: "A Logical Data Model and Translation Software for Scenario Representations in Mission-Level Simulations," J. F. Schloman, 2005 Spring Simulation Interoperability Workshop, San Diego, CA (Mar 2005)





# Example: Interacting Simulations for a Crisis Management and Evacuation System

---

- Design layout of a chemical sensor system for a downtown urban area, and a traffic management system for evacuation during a crisis
- Component Simulations
  - Explosive detonation causing railcar rupture
  - Chemical source strength simulation
  - Chemical plume dispersion simulation
  - Chemical sensor simulation
  - Emergency management command and control simulation
  - Traffic flow simulation

# Interacting Simulations for a Crisis Management and Evacuation System – Scenario Use Case

5. Emergency responders react

4. Chlorine cloud moves toward downtown

3. Second explosion, 15 minutes later

2. First explosion

1. Train with railcars containing chlorine approaches

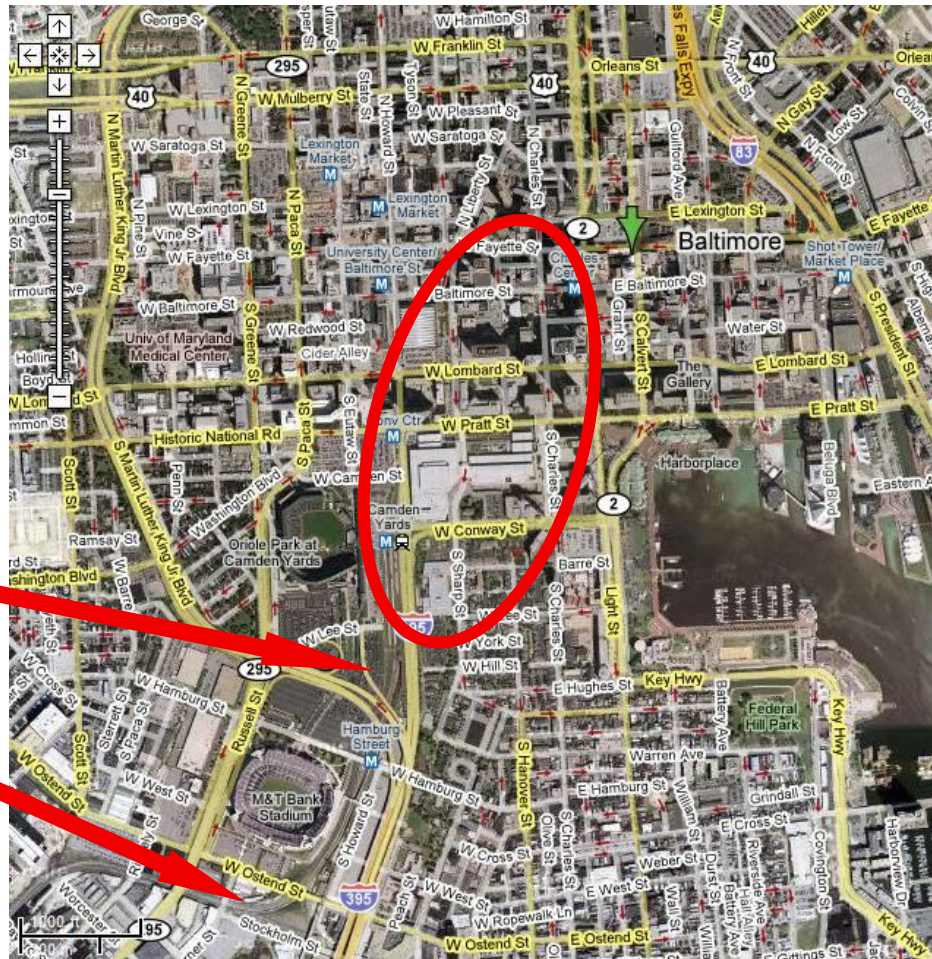

6. News reports issued

7. Local commanders order evacuation

8. Police in protective gear dispatched to intersections

9. Chemical sensors deployed

10. Local populace reacts, traffic builds on roads

Source: GoogleEarth



# Interacting Simulations for a Crisis Management and Evacuation System – Design Considerations

- Railcar rupture simulation component
  - Needs no feedback from other simulation components
  - Can be executed in advance
- Simulation of airborne transport through 3D cityscape
  - Requires many processors, cannot run in real time – 3 steps:
    - Generation of wind field (slower than real time)
    - Insertion of pollutant into wind field (slower than real time), forming data file of chlorine concentrations
    - Extraction of chlorine concentrations in real time from data file
- Airborne transport depends on release rate of chlorine
  - So chlorine release simulation, although not computationally intensive, needs to be executed in advance
- Remaining three functions (sensing, command and control, and traffic flow) can be performed in real time (or faster) as part of simulation federation

# Interacting Simulations for a Crisis Management and Evacuation System – Block Diagram

## Non-Real-Time Simulation Components

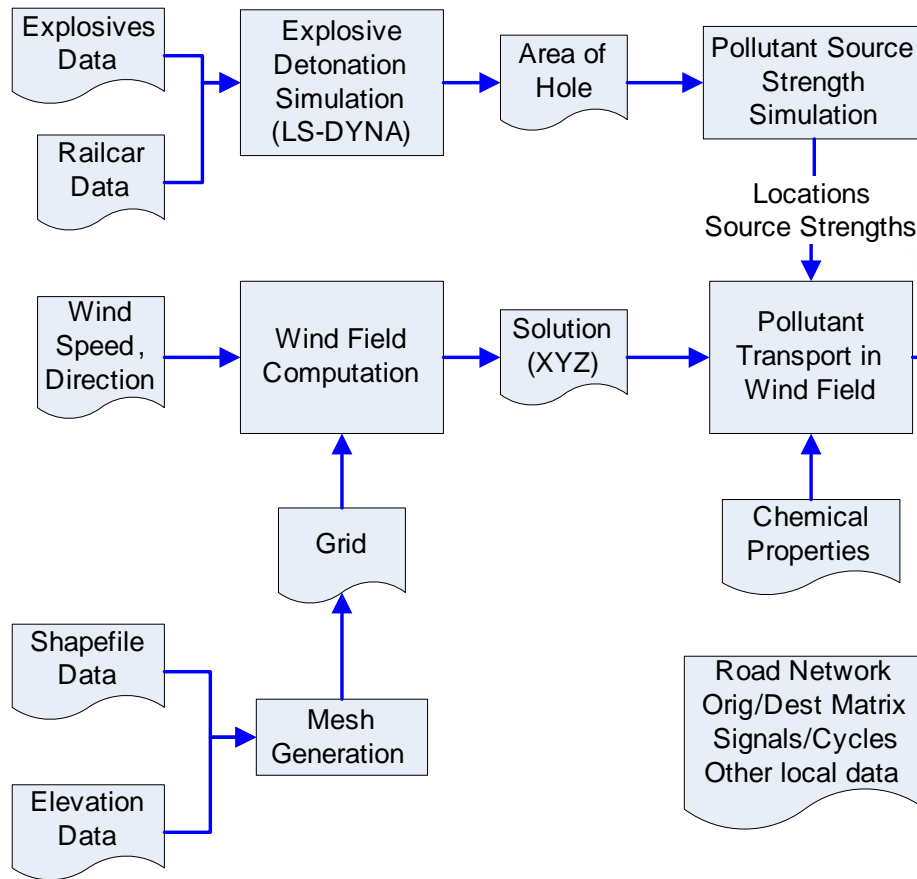

## Real-Time Simulation Federation Components – Federated Using the High Level Architecture (HLA)

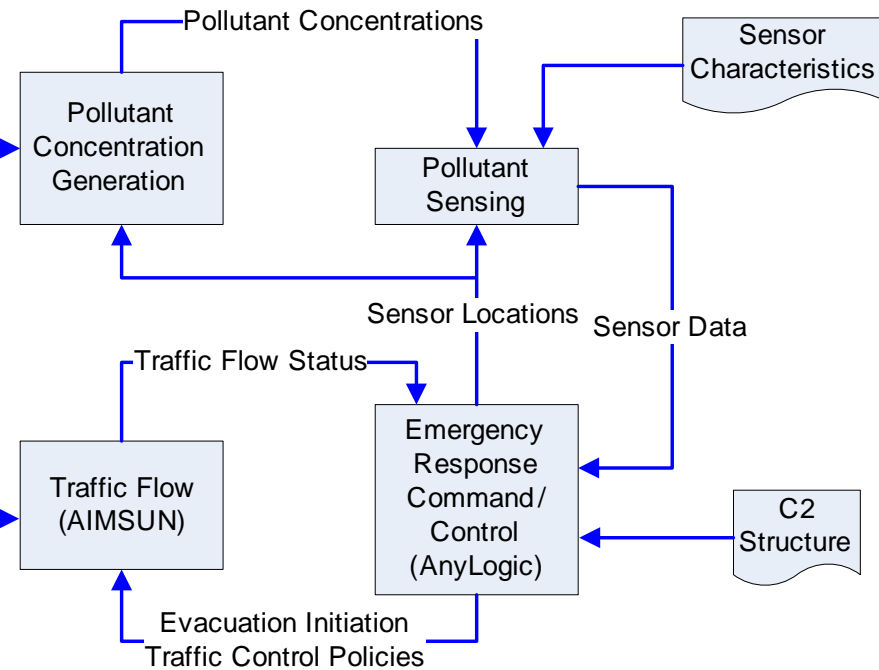

# Example: Interacting Simulations for a (Mobile) Missile System

- Simulations of Interest
  - Transporter-Erector-Launcher – Structural Mechanics
  - Missile structure – Structural Mechanics (During Transport and Flight)
  - Propulsion – Thrust, Heat Generation
  - Thermal – Heat Transfer to Nozzle and Missile Structure
  - Guidance and control – 6-dof Flight Simulation
  - Fluid dynamics – Vane Control Effectiveness



Pershing 1A missile  
(Source: U.S. Army)

# Interacting Simulations for a (Mobile) Missile System: Step 1: Where might there be interactions?

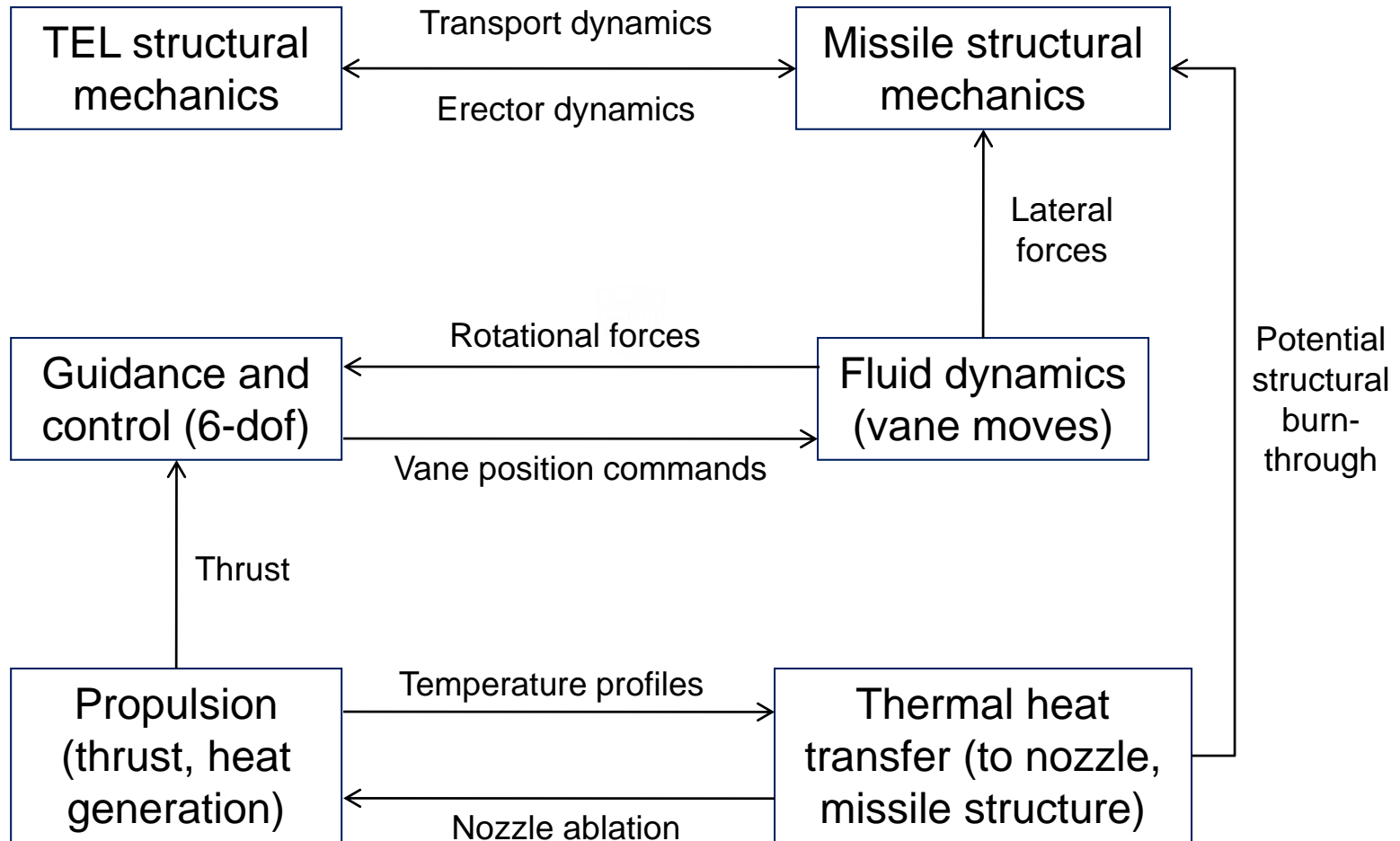





# Interacting Simulations for a (Mobile) Missile System: Step 2: Are the interactions one-way or two-way? (1 of 4)

- Interactions between Propulsion and Guidance and control are one-way, during each missile stage's burn time.
- Thermal heat transfer to Missile structure and Vane control to Missile structure are one-way.
- For these, simulations of the first can be run to completion, and their outputs input to simulations of the second. ("Batch runs" can be used.)

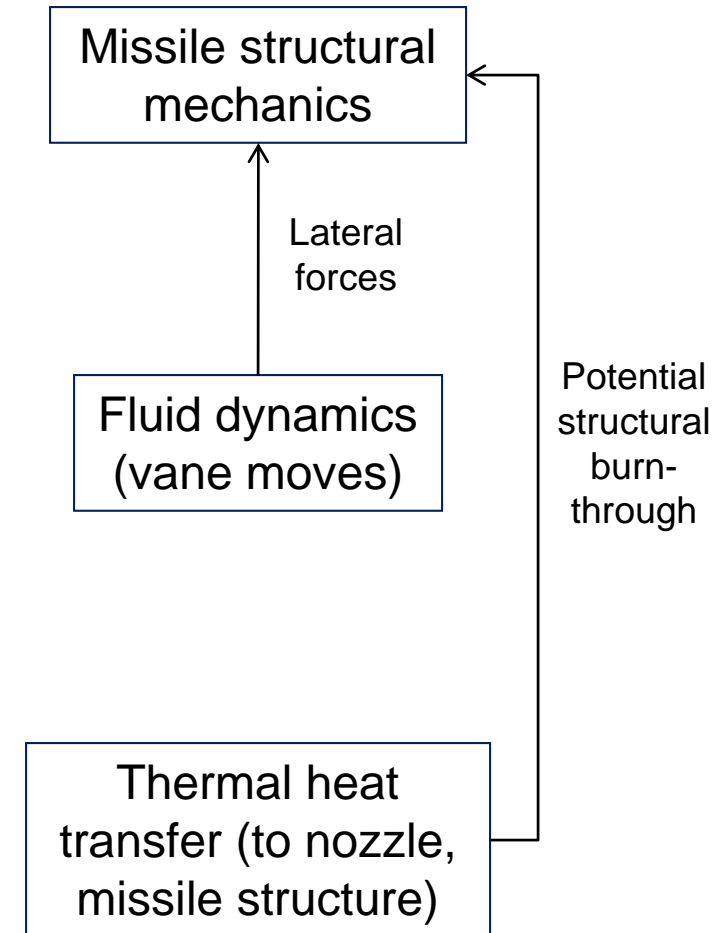
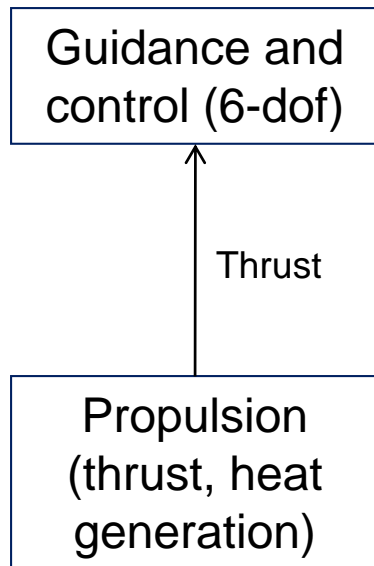



# Interacting Simulations for a (Mobile) Missile System: Step 2: Are the interactions one-way or two-way? (2 of 4)

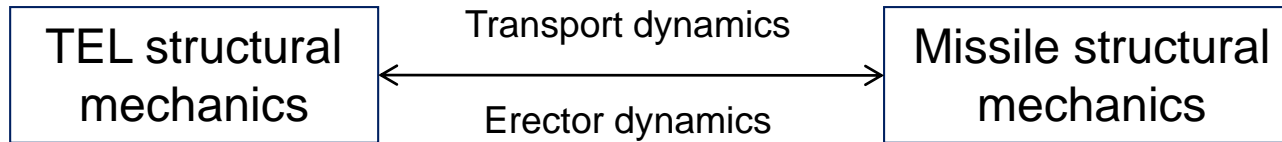

- Pre-launch dynamics between the TEL and the missile are two-way:
  - During transport, the missile and TEL cradle interact in a relatively static configuration
  - When the erector is activated, the missile and TEL erector cradle interact dynamically
- As the concern is structural mechanics for both the missile structure and the TEL, a unified (tightly coupled) structural mechanics simulation of both can be constructed





## Interacting Simulations for a (Mobile) Missile System: Step 2: Are the interactions one-way or two-way? (3 of 4)

- The interactions between Guidance and control and Fluid dynamics of vane movements are two-way
  - Vane position commands cause vane movement
  - Vane movement produces rotational forces on the missile
- Usually, simulations (computational fluid dynamics codes or wind tunnel tests) are run in advance to calculate rotational forces as a function of vane position, missile angle of attack, and relative velocity
  - This permits the calculation of rotational forces to be embedded in the Guidance and control simulation
- For complex interactions, the Guidance and control and Fluid dynamics of vane movement could be in separate simulations that interchange data during run-time

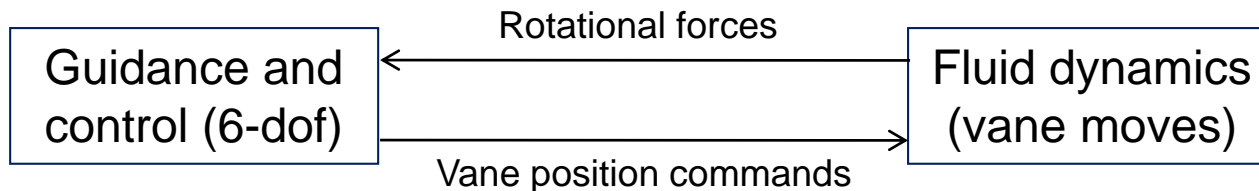

# Interacting Simulations for a (Mobile) Missile System: A few basics on solid rocket propulsion and nozzles

- After ignition, solid fuel burns radially out from center toward motor casing
- Fuel burn creates hot gases that exit through nozzle, creating thrust
- Thrust depends on many factors, including nozzle throat area
- Nozzle lining ablates over time, slightly increasing nozzle throat area

Known:

$p_t$  = Total Pressure       $\gamma$  = Specific Heat Ratio  
 $T_t$  = Total Temperature     $R$  = Gas Constant  
 $p_0$  = Free Stream Pressure    $A$  = Area

Mass Flow Rate:  $\dot{m} = \frac{A^* p_t}{\sqrt{T_t}} \sqrt{\frac{\gamma}{R}} \left(\frac{\gamma+1}{2}\right)^{-\frac{\gamma+1}{2(\gamma-1)}}$

Exit Mach:  $\frac{A_e}{A^*} = \left(\frac{\gamma+1}{2}\right)^{-\frac{\gamma+1}{2(\gamma-1)}} \frac{\left(1 + \frac{\gamma-1}{2} M_e^2\right)^{\frac{\gamma+1}{2(\gamma-1)}}}{M_e}$

Exit Temperature:  $\frac{T_e}{T_t} = \left(1 + \frac{\gamma-1}{2} M_e^2\right)^{-1}$

Exit Pressure:  $\frac{p_e}{p_t} = \left(1 + \frac{\gamma-1}{2} M_e^2\right)^{-\frac{\gamma}{\gamma-1}}$

Exit Velocity:  $V_e = M_e \sqrt{\gamma R T_e}$

**Thrust:  $F = \dot{m} V_e + (p_e - p_0) A_e$**

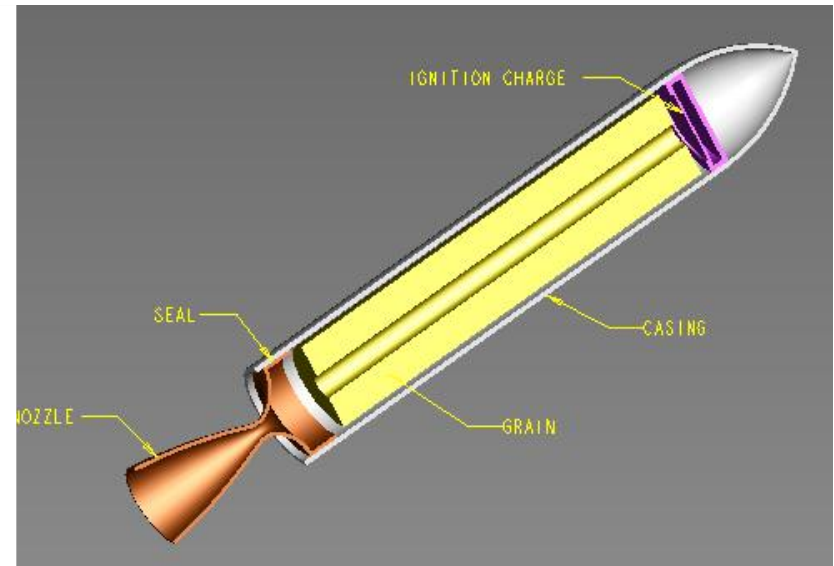
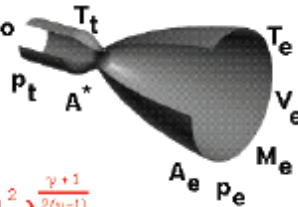

Solid rocket motor thrust equations (source: NASA)

Solid rocket motor (source: Wikipedia Commons)



## Interacting Simulations for a (Mobile) Missile System: Step 2: Are the interactions one-way or two-way? (4 of 4)

- The interactions between Propulsion and Thermal heat transfer are two-way, because exit gas temperature causes ablation at nozzle throat
- Because of complexity of interactions, for detailed calculations of thrust vs. time, would want to have Propulsion and Thermal heat transfer simulations interact at run-time

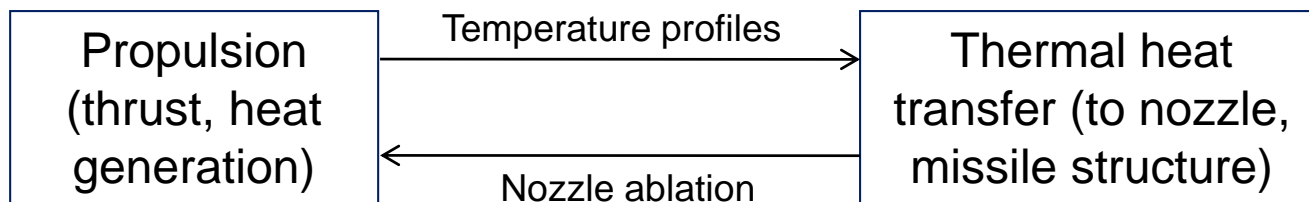



## Example: Construction of a Simulation Environment for an Underwater Vehicle's Navigation and Sensor Data Systems

---

- Consider the integration of a tethered underwater vehicle's navigation and sensor systems
- The vehicle will include:
  - A forward-looking obstacle-avoidance sonar
  - Two side-scan sonars (one looking left, one looking right)
  - Two downward-looking full-motion video cameras
  - One downward-looking high-resolution electronic still camera
  - A four-head downward-looking Doppler sonar for navigation
- Prior to receiving the above imaging and navigation sensors, how could simulations be used (as stimulators) to prepare for the sensors' integration with the vehicle's navigation and sensor data acquisition systems?

# Simulation Environment for an Underwater Vehicle's Navigation and Sensor Data Systems – Potential System Design

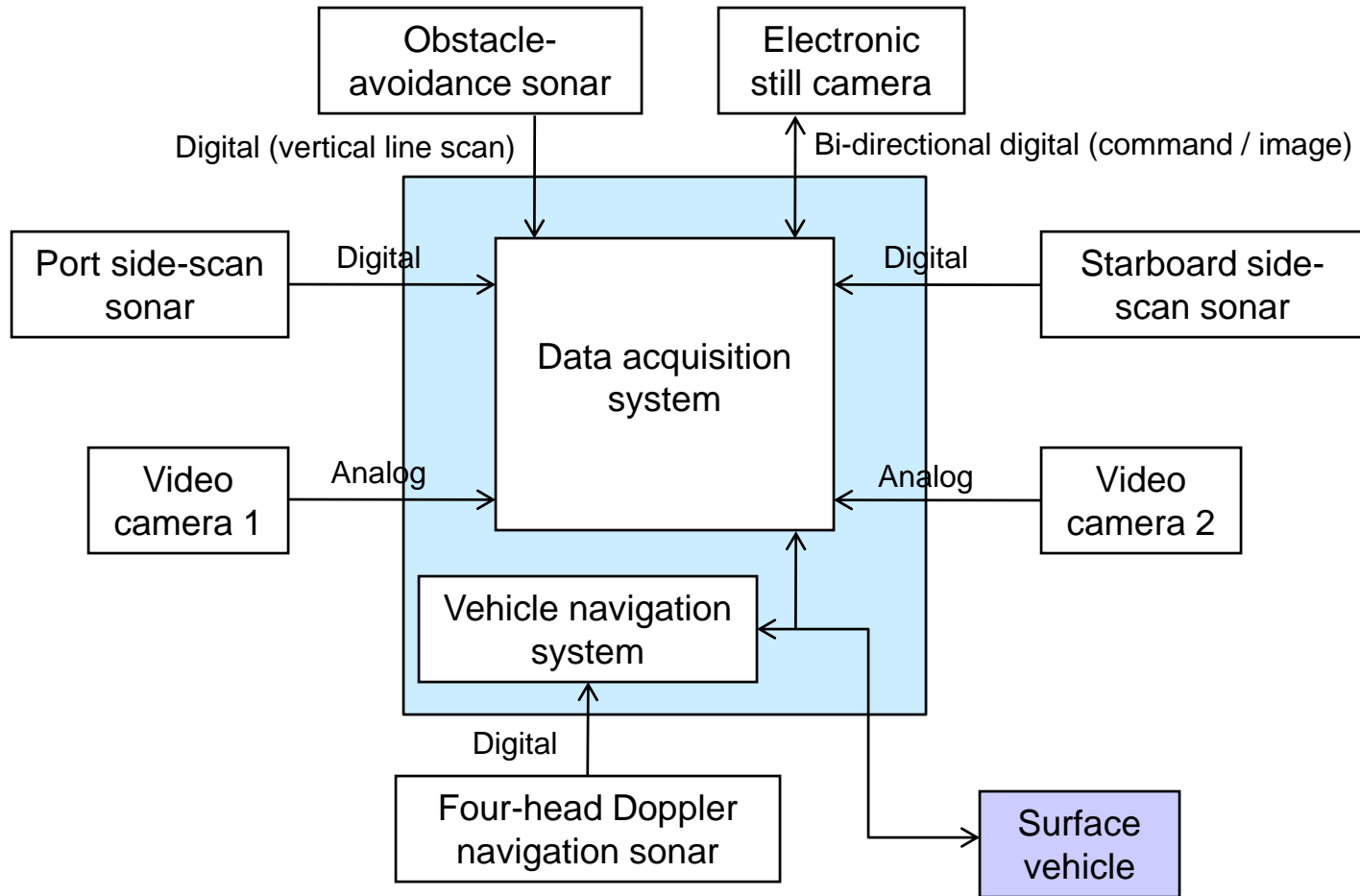



# Simulation Environment for an Underwater Vehicle's Navigation and Sensor Data Systems – Considerations

- In the system being built, what are the interfaces between the imaging / navigation sensors and the vehicle's navigation and sensor data acquisition systems?
  - Are the interfaces analog or digital?
  - For analog interfaces, what analog data communication standards are being used (video, acoustic, other)?
  - For digital interfaces:
    - What digital data communication hardware standards are being used (e.g., RS-232, Ethernet, USB)?
    - What data formatting techniques are being used (e.g., XML, byte-ordering scheme, proprietary)?
    - What syntax is being used for the data in each data transmission frame?
    - What is the frame transmission rate?
- To what degree does testing require that simulated data be representative of expected real data?
  - Are only the data rate and data format/syntax important?
  - Do images need to be realistic (e.g., if the data acquisition system employs feature recognition to make a decision)?
  - Does navigation sensor data need to be used to develop a simulated track?

# Simulation Environment for an Underwater Vehicle's Navigation and Sensor Data Systems – Video Cameras

- Design note: Analog video camera signals are merely re-transmitted in analog form to the surface vehicle for viewing by operators and possible recording.
- Therefore the video camera simulations (stimulators) can be simple hardware video sources, even VCRs with arbitrary interfaces

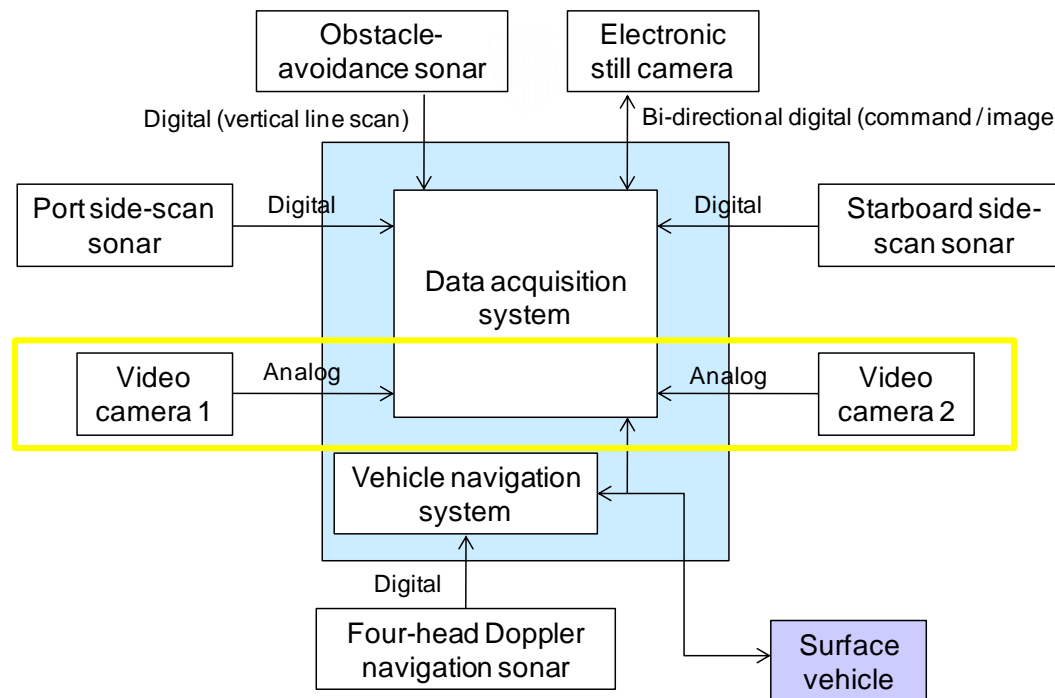

# Simulation Environment for an Underwater Vehicle's Navigation and Sensor Data Systems – Side-scan Sonars

- Design note: Each side-scan sonar produces a “line” of 1024 pixels with black-and-white intensity from 0 to 255, once per second; lines are merely re-transmitted to the surface vehicle.
- Therefore the side-scan sonar simulations (stimulators) need only replicate the data rates of the sensors.

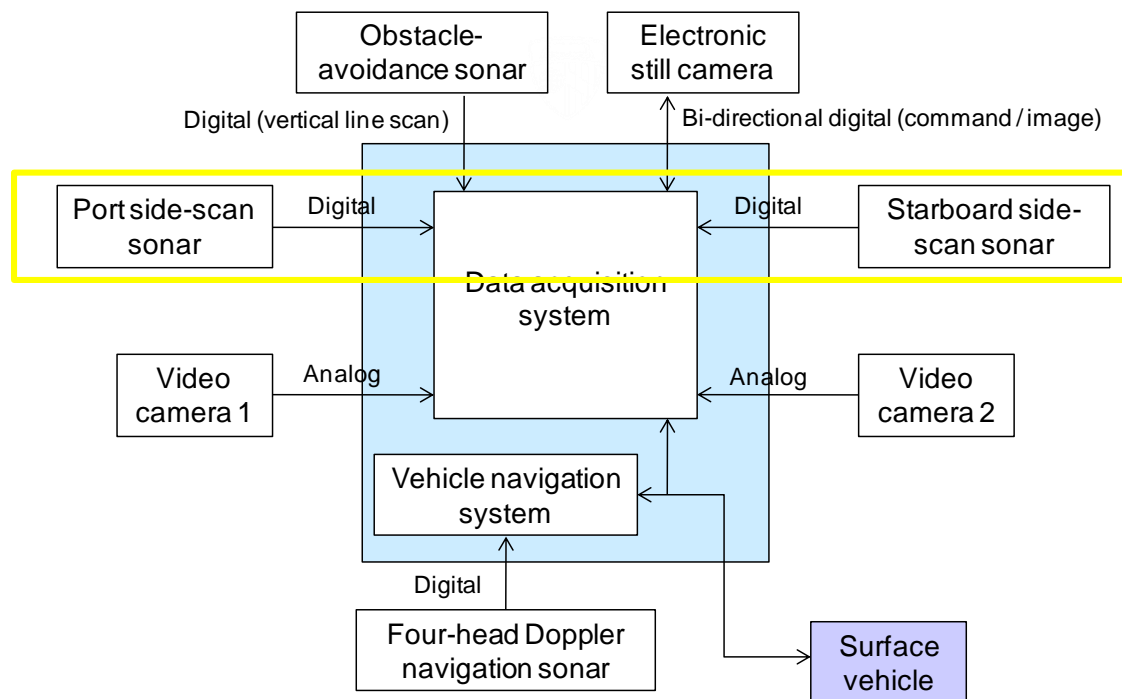



# Simulation Environment for an Underwater Vehicle's Navigation and Sensor Data Systems – Obstacle Avoidance Sonar

- Design notes:
  - The obstacle avoidance sonar produces a “vertical line” of 256 pixels (covering a 30-degree vertical field of view) with black-and-white intensity from 0 to 255, 5 times per second, sweeping a 30-degree horizontal field of view in 30 seconds to form a 256x150 continually-updated image.
  - The data acquisition system generates an alarm when a “dark object” of a certain size is in the center of the field of view.
- Therefore the obstacle-avoidance sonar simulation (stimulator) must provide, at the required rate, representative data that will show both no dark objects and an occasional realistic dark object over time.

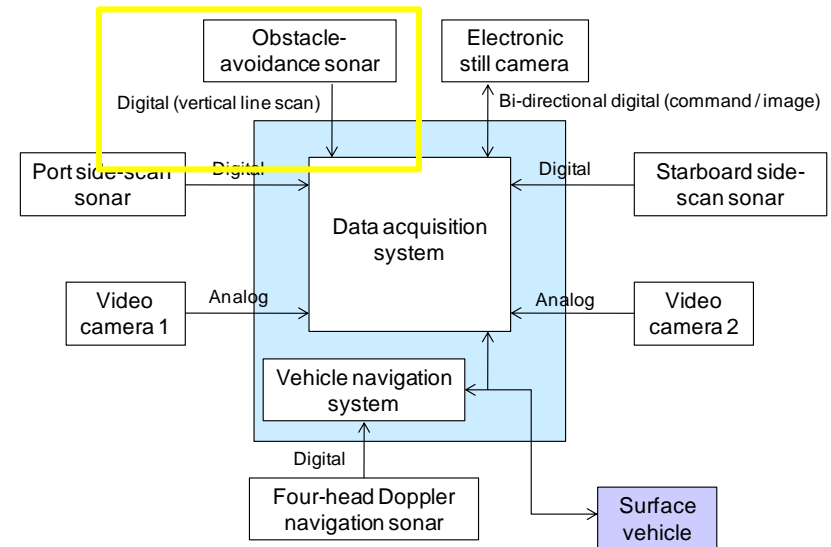

# Simulation Environment for an Underwater Vehicle's Navigation and Sensor Data Systems – Electronic Still Camera

- Design note: The electronic still camera, upon a command from the data acquisition system, takes a single 1024 x 1024 pixel (with black-and-white intensity from 0 to 255), at a maximum rate of once per second. Images are merely re-transmitted to the surface vehicle.
- Therefore the electronic still camera simulation (stimulator) needs to replicate the data rate (up to 8 megabits per second) and pixel transmission order of the camera, upon receipt of a command.

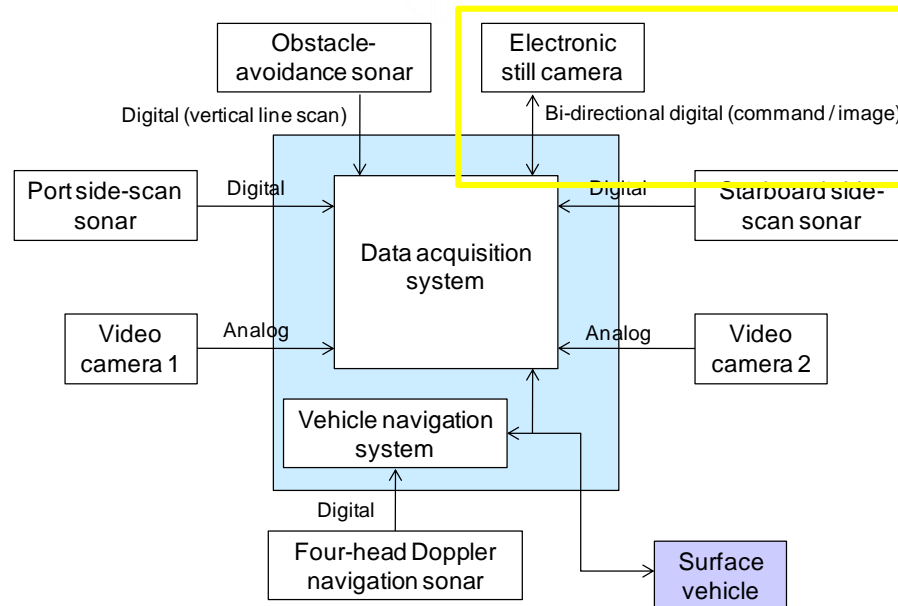

# Simulation Environment for an Underwater Vehicle's Navigation and Sensor Data Systems – Doppler Nav Sonar

- Design note: The Doppler navigation sonar transmits four digital values (from 0 to 4095), once per second, representing fore, port, aft, and starboard speeds relative to the bottom of the body of water. The vehicle navigation system uses these values to compute an instantaneous vehicle velocity and to produce a continuous x-y track relative to the bottom.
- Therefore the Doppler navigation sonar simulation (stimulator) needs to provide an operationally realistic (within vehicle propulsion capabilities), time-consistent (second-to-second) set of four speed values to the vehicle navigation system).

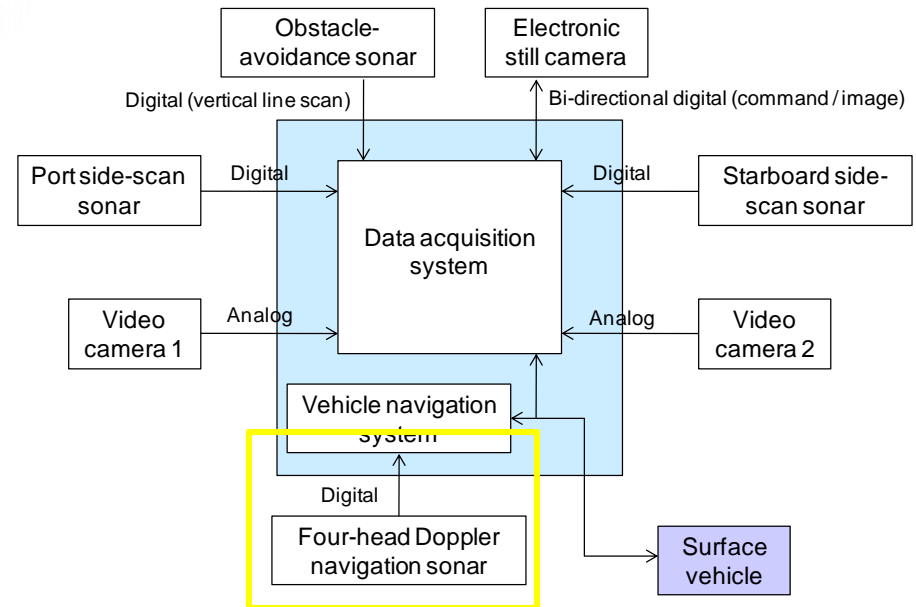



## Example: Construction of the M&S Portions of a Test and Evaluation Master Plan (TEMP)

---

- Consider a Test and Evaluation Master Plan for a ballistic missile interceptor missile, which could include descriptions of such T&E activities as
  - Subsystem tests of radar seeker
  - Subsystem tests of focal plane array
  - Wind tunnel tests using scaled missile model
  - Static tests (on test stand) of propulsion subsystem
  - Flight tests on a test range
  - Post-flight evaluation
- What types of models and simulations are needed for each T&E activity?
  - Where might simulations be used? Where might models be used?
  - For the simulations, which are live? Which are virtual? Which are constructive?



## Extracts from DoD Instruction 5000.02 Regarding Test and Evaluation Master Plan (TEMP)

---

- Test and Evaluation Master Plan (TEMP). ... The TEMP shall describe planned developmental, operational, and live-fire testing, including measures to evaluate the performance of the system during these test periods; an integrated test schedule; and the resource requirements to accomplish the planned testing. ...
  - (6) Appropriate use of accredited models and simulation shall support DT&E, IOT&E, and LFT&E.

DT&E: Developmental Test & Evaluation

OT&E: Operational Test & Evaluation

LFT&E: Live Fire Test and Evaluation

Source: DoD Instruction 5000.02, *Operation of the Defense Acquisition System*, December 8, 2008



# References to Modeling and Simulation in Recommended TEMP Format

---

- **PART III – TEST AND EVALUATION STRATEGY**
  - 3.3 DEVELOPMENTAL EVALUATION APPROACH
    - 3.3.3 Modeling and Simulation
  - 3.4 LIVE FIRE EVALUATION APPROACH
    - 3.4.2 Modeling and Simulation
  - 3.6 OPERATIONAL EVALUATION APPROACH
    - 3.6.2 Modeling and Simulation
- **PART IV – RESOURCE SUMMARY**
  - 4.1 INTRODUCTION
    - 4.1.7 Models, Simulations, and Test-beds

Source: Annex to *Defense Acquisition Guidebook*, Section 9.10, “Test and Evaluation Master Plan (TEMP) Recommended Format”



# Developmental Test & Evaluation: Tests of Interceptor Sensor Subsystems

---

- Radar seeker subsystem testing
  - Intended to estimate performance of the in-development seeker
  - Employs hardware-in-the-loop (HWIL) simulation
    - Radar seeker is a live simulation component (the real seeker)
    - Target object in an anechoic chamber is a constructive simulation component (a simulation of a potential target)
- Focal plane array subsystem testing
  - Intended to estimate performance of the in-development array
  - Employs HWIL simulation
    - Focal plane array is a live simulation component (the real array)
    - Target representation is a constructive simulation component (e.g., an array of light-emitting devices representing various target and background signatures)
  - May also have a software-in-the-loop (SWIL) component
    - Image processing software embedded in seeker system for target recognition and discrimination



# Developmental Test & Evaluation: Aerodynamic and Propulsion Testing

---

- Wind tunnel testing using scaled missile model
  - Intended to estimate aerodynamic performance of missile at various speeds and angles of attack
  - Employs a physical model of the missile body
  - Wind tunnel test itself is a simulation
    - Wind field is a constructive environmental simulation component (of the real relative wind the missile would see during actual flight)
- Static testing (on test stand) of propulsion subsystem
  - Intended to estimate thrust vs. time of the missile interceptor
  - Employs HWIL simulation
    - Missile stage containing propellant and ignition system is a live simulation component (the real missile stage)





# DT&E and OT&E (Potentially Combined): Flight Tests and Post-Flight Evaluation

- Flight test on a test range
  - Intended to measure interceptor performance in varied realistic conditions
  - Pre-flight predictions are done using constructive six-degree-of-freedom (6-dof) simulations (for test design and range safety purposes)
  - For flight test itself
    - Interceptor and target missile are live simulation components
    - If interceptor launch is under operator control, the operator is a live simulation component
- Post-flight evaluation
  - Intended to evaluate single- and multiple-flight test performance
  - Post-flight “predictions” (e.g., using actual wind conditions) are often done using 6-dof simulations (for comparison to telemetry data)
  - Using multiple-flight data, can use data to create better model of interceptor guidance and control system (e.g., using Kalman filtering approach)



# Example: Repair Process for a Deployed Military System Component

---

- Consider the repair process for a deployed military system component (radio) associated with a communications van in theater
  - When the radio malfunctions, what is the initial repair process?
  - If the radio cannot be fixed in place, where does it go?
  - How many levels of repair are implemented?
  - What is the spare parts strategy and inventory?
- How would you model the repair process using a tool such as Arena?



# Example Levels/Sequence of Repair

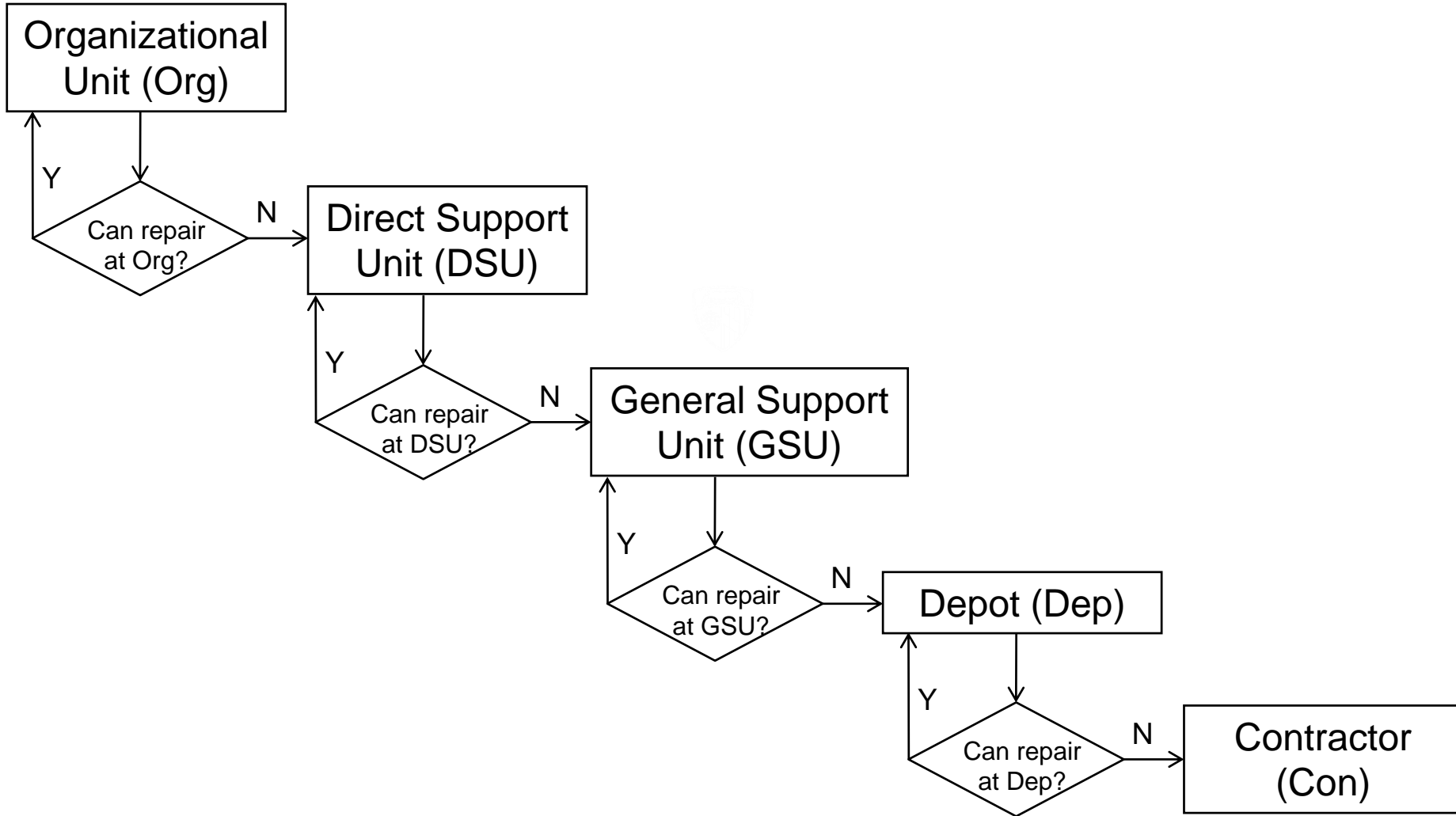



# Modeling the Repair Process

- Each possible point of repair has a probability that the radio can be repaired there
  - If it can be repaired there, there is a distribution of repair times
  - If it cannot be repaired there:
    - There is a distribution of times it takes to come to that decision
    - There is a transportation time to the next level of repair

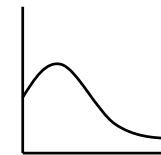
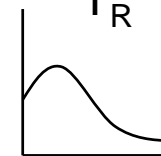
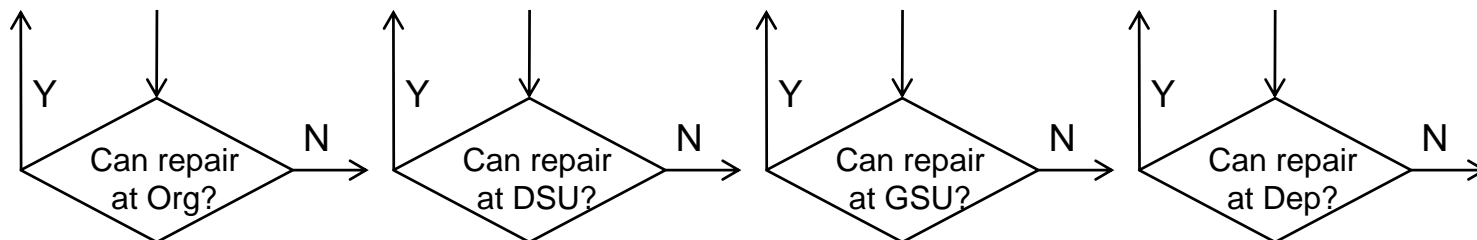
 $P_R$  $T_R$  $T_D$  $T_T$ 



# Modeling the Repair Parts Supply Chain

- Modeling Issues
  - Based on reliability models, how many of each radio part should be stored at each repair point?
  - When a spare part is used at a repair point, from where is a replacement requested?
  - Based on reliability/availability models and logistics/transportation cost issues, at what spare parts inventory level at a given repair point should replacements be shipped?

Organizational  
Unit (Org)

Direct Support  
Unit (DSU)

General Support  
Unit (GSU)

Depot (Dep)

Contractor  
(Con)